

## Basic Clutch Information

### Guide to Clutch Identification and Catalog Use

In our efforts to make this catalog as complete and as useful as possible, clutches are listed in three different sections.

1. Specifications Section (listed in ascending order by diameter)
2. Illustration or Photo Section (listed in our numeric order within by manufacturer)
3. Cross Reference Section (OEM service numbers and/or numbers stamped on the clutch are listed in the cross reference section in the back of this catalog)

The clutch used on a particular truck depends on the type of compressor selected from an option list when the truck was first assembled. However, after miles of service, original parts most likely have been replaced. For whatever reason, a truck originally equipped with a reciprocating compressor may now be using a rotary type or possibly a single groove clutch has been replaced with a double groove. To assure your customer gets the right part the first time, it is important to identify the compressor the clutch is to be used on, and the characteristics or specifications of the clutch. If possible, check for label or stamped numbers on the clutch body or the coil assembly to identify the clutch.

If the clutch marking or label is illegible, the following information will be needed:

1. Compressor Make and Model
2. Voltage - 12v or 24v
3. Diameter of Clutch Pulley
4. Number of Grooves; Width of Drive Belt
5. A-B Distance or Gauge Line

For your convenience, a "How to Measure" is shown in each clutch section to help in identification.

Clutches are listed in alphabetical sequence by the name of the compressor manufacturer the clutch is to be installed on.



# CLUTCHES

<b>BLISSFIELD (Tecumseh) .....</b>	<b>191</b>	<b>SANKYO (see Sanden).....</b>	<b>198</b>
<b>CCI/YORK STYLE .....</b>	<b>191</b>	<b>SELTEC .....</b>	<b>203</b>
<b>DENSO .....</b>	<b>195</b>	<b>TAMA HD (see Seltec) .....</b>	<b>203</b>
<b>DIESEL KIKI (see Seltec) .....</b>	<b>203</b>	<b>TECUMSEH (see Blissfield).....</b>	<b>191</b>
<b>FORD .....</b>	<b>196</b>	<b>YORK STYLE .....</b>	<b>191</b>
<b>ICE (see Seltec) .....</b>	<b>203</b>	<b>ZEXEL (see Seltec).....</b>	<b>203</b>
<b>SANDEN .....</b>	<b>198</b>		

### Clutch Related Items

Idler Pulleys .....	205
Eccentrics .....	205
Clutch Plate Removal Tools .....	458
Clutch Pully/Pullers .....	458

# BLISSFIELD / YORK STYLE — CLUTCHES

**BLISSFIELD / YORK STYLE**

HOW TO MEASURE:  
IF PART NUMBER ON CLUTCH BEING REPLACED CANNOT BE READ, USE THE FOLLOWING PROCEDURE TO DETERMINE REQUIRED CLUTCH PART NUMBER.

1. DETERMINE IF 12 OR 24 VOLT (Black Wire = 12V, Green Wire = 24V).
2. DETERMINE IF CLUTCH IS SINGLE, DOUBLE OR POLY GROOVE.
3. MEASURE OUTSIDE DIAMETER OF PULLEY.
4. MEASURE WIDTH OF PULLEY GROOVE:
  - a. Single and Double Groove = measure the width of pulley groove.
  - b. Poly Groove = count the number of grooves.
5. MEASURE ACCURATELY THE A-B DISTANCE:
  - a. Single and Double Groove = measure the distance from the compressor mounting hole on the side of the compressor to the middle of the rear belt groove on the pulley (the rear belt groove is closest to the compressor).
  - b. Poly Groove = measure the distance from the compressor mounting hole on the side of the compressor to the middle of the first groove on the pulley.
6. DETERMINE THE NUMBER OF WIRES.













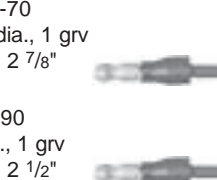













To convert millimeter to inches divide millimeters by 25.4

## Blissfield / YORK STYLE (clutches are listed in ascending order by diameter)

PART#	DIA.	GROOVES	WIDTH	A-B DIST.	VOLT	DESCRIPTION
5029	5 3/8"	Poly 8	.14"	1 5/8"	12	single wire IHC Plug
5030	5 7/8"	Poly 6	.14"	1 5/8"	12	single wire IHC Plug
5129	5 7/8"	Poly 6	.14"	1 5/8"	12	two wire coil Metripak
5126	5 7/8"	Poly 6	.14"	2"	12	far forward, 2 wire Metripak
5127	5 7/8"	Poly 6	.14"	2"	12	far forward, 1 wire Weatherpak
5027	6"	1	1/2"	2 5/16"	12	single wire
5031	6"	1	1/2"	2 11/16"	12	single wire Weatherpak
5131	6"	1	1/2"	2 11/16"	12	single wire IHC Plug
5011	6"	1	1/2"	2 1/2"	12	single wire Male Bullet - Limited supply
5125	6"	1	1/2"	2 11/16"	12	two wire coil Metripak
5028	6"	1	5/8"	2 1/4"	12	single wire Male Bullet
5032	6"	1	5/8"	2 11/16"	12	single wire IHC Plug
5009	6 1/2"	1	1/2"	2 7/8"	12	single wire Male Bullet - Limited supply
5044	6"	2	1/2"	1 3/4" / 2 1/4"	12	single wire Male Bullet
5144	6"	2	1/2"	1 3/4" / 2 1/4"	12	single wire w/diode & Weatherpak
5145	6"	2	1/2"	1 3/4" / 2 1/4"	12	two wire coil Metripak
5147	6"	2	1/2"	2 1/4"	12	mini clutch version (5281) Metripak
5045	6"	2	1/2"	1 3/4" / 2 1/4"	24	single wire Male Bullet
5143	6"	2	1/2"	2 11/16"	12	single wire IHC Plug
5128	6 1/8"	Poly 8	.14"	1 5/16"	12	two wire coil Metripak
5046	6 3/4"	1	1/2"	3"	12	limited availability
5040	6 3/4"	1	1/2"	1 3/4"	12	single wire Male Bullet
5096	6 3/4"	1	1/2"	2 11/16"	12	single wire Male Bullet
5033	6 3/4"	1	1/2"	3 1/8"	12	single wire Male Bullet
5036	6 3/4"	1	5/8"	1 3/4"	12	single wire Male Bullet
5062	6 3/4"	1	5/8"	1 15/16"	12	single wire Male Bullet
5038	6 3/4"	1	5/8"	2 11/16"	12	single wire Male Bullet
5037	6 3/4"	1	5/8"	2 13/16"	12	single wire Male Bullet
5039	6 3/4"	1	5/8"	3 1/8"	12	single wire Male Bullet
5043	6 3/4"	1	13/16"	1 25/32"	12	single wire Male Bullet
5034	6 3/4"	1	13/16"	2 13/16"	12	single wire Male Bullet
5047	6 3/4"	1	3/4"	3 1/16"	12	single wire Male Bullet
5141	6 3/4"	2	1/2"	2 1/4" / 2 3/4"	12	single wire IHC Plug
5041	7"	2	1/2"	1 3/4" / 2 1/4"	12	single wire Male Bullet
5042	7"	2	1/2"	2 1/4"	24	single wire Male Bullet
5063	7 3/8"	1	3/4"	1 15/16"	12	single wire Male Bullet











# CLUTCHES — BLISSFIELD / YORK STYLE

Listed in ascending order by our part number

<p>While Supplies Last</p>  <p><b>5009</b> OE# 1406-70 12v, 6 1/2" dia., 1 grv A-B Dist. - 2 7/8"</p>  <p><b>5011</b> OE# 1436-90 12v, 6" dia., 1 grv A-B Dist. - 2 1/2"</p>  <p><b>5027</b> OE# 505964 12v, 6" dia., 1 grv A-B Dist. - 2 5/16"</p>	 <p><b>5028</b> OE# 1466-70 Volt - 12V Dia. - 6" Grooves - 1 Width - 5/8" A-B Dist - 2 1/4"</p>  <p>1 Wire Plug</p>	 <p><b>5029</b> OE# 515376, MAN-03 Volt - 12V Dia. - 5 3/8" Grooves - Poly 8 Width - .14" A-B Dist.- 1 5/8"</p>  <p>1 Wire IHC Plug</p>	 <p><b>5030</b> OE# 513352, MAN-03 Volt - 12V Dia.-5 7/8" Grooves - Poly 6 Width-.14" A-B Dist.- 1 5/8"</p>  <p>1 Wire IHC Plug</p>
 <p><b>5031</b> OE# 502409 Volt - 12V Dia. - 6" Grooves - 1 Width - 1/2" A-B Dist.- 2 11/16"</p>  <p>1 Wire Plug Weatherpak</p>	 <p><b>5032</b> OE# 503879, 515528, MAN-06 Volt - 12V Dia. - 6" Grooves - 1 Width - 5/8" A-B Dist.- 2 11/16"</p>  <p>1 Wire Plug</p>	 <p><b>5033</b> OE# 502740 Volt - 12V Dia. - 6 3/4" Grooves - 1 Width - 1/2" A-B Dist.- 3 1/8"</p>  <p>1 Wire Plug</p>	 <p><b>5034</b> OE# 1406-20, 502745 Volt - 12V Dia. - 6 3/4" Grooves - 1 Width - 13/16" A-B Dist.- 2 13/16"</p>  <p>1 Wire Plug</p>
 <p><b>5036</b> OE# 502731 Volt - 12V Dia. - 6 3/4" Grooves - 1 Width - 5/8" A-B Dist.- 1 3/4"</p>  <p>1 Wire Plug</p>	 <p><b>5037</b> OE# 502736 Volt - 12V Dia. - 6 3/4" Grooves - 1 Width - 5/8" A-B Dist.- 2 13/16"</p>  <p>1 Wire Plug</p>	 <p><b>5038</b> OE# 502743 Volt - 12V Dia. - 6 3/4" Grooves - 1 Width - 5/8" A-B Dist.- 2 11/16"</p>  <p>1 Wire Plug</p>	 <p><b>5039</b> OE# 502741 Volt - 12V Dia. - 6 3/4" Grooves - 1 Width - 5/8" A-B Dist.- 3 1/8"</p>  <p>1 Wire Plug</p>

# BLISSFIELD / YORK STYLE — CLUTCHES

Listed in ascending order by our part number (continued)

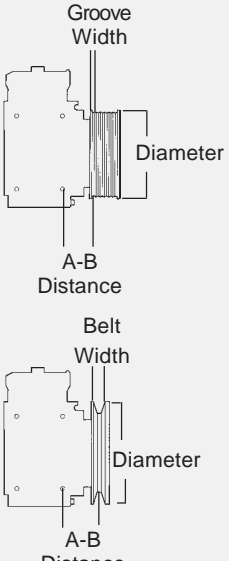
 <p><b>5040</b> OE# 502730 Volt - 12V Dia. - 6 3/4" Grooves - 1 Width - 1/2" A-B Dist.- 1 3/4"    1 Wire Plug</p>	 <p><b>5041</b> OE# 332334, 502742, MAN-7A Volt - 12V Dia. - 7" Grooves - 2 Width - 1/2" A-B Dist.- 1 3/4" / 2 1/4"    1 Wire</p>	 <p><b>5042</b> OE# 1411-51 Volt - 24V Dia. - 7" Grooves - 2 Width - 1/2" A-B Dist - 2 1/4"    1 Wire Plug</p>	 <p><b>5043</b> OE# 502744 Volt - 12V Dia. - 6 3/4" Grooves - 1 Width - 13/16" A-B Dist.- 1 25/32"    1 Wire Plug</p>
 <p><b>5044</b> OE# 332639, MAE-6AR, MA-6A Volt - 12V Dia. - 6" Grooves - 2 Width - 1/2" A-B Dist.- 1 3/4" / 2 1/4"    1 Wire</p>	 <p><b>5045</b> OE# 1411-35 Volt - 24V Dia. - 6" Grooves - 2 Width - 1/2" A-B Dist.- 1 3/4" / 2 1/4"    1 Wire</p>	 <p><b>5046</b> OE# K332-28, K332-45 Volt - 12V Dia. - 6 3/4" Grooves - 1 Width - 1/2" A-B Dist.- 3" <i>White Supplies Last</i></p>	 <p><b>5047</b> OE# 508821 Volt - 12V Dia. - 6 3/4" Grooves - 1 Width - 3/4" A-B Dist.- 3 1/16"    1 Wire Plug</p>
 <p><b>5062</b> OE# 502733 Volt - 12V Dia. - 6 3/4" Grooves - 1 Width - 5/8" A-B Dist.- 1 15/16"    1 Wire Plug</p>	 <p><b>5063</b> OE# 502400 Volt - 12V Dia. - 7 3/8" Grooves - 1 Width - 3/4" A-B Dist.- 1 15/16"    1 Wire Plug</p>	 <p><b>5096</b> OE# 1406-23, CH4.91G Volt - 12V Dia. - 6-3/4" Grooves - 1 Width - 1/2" A-B Dist.- 2 11/16"    1 Wire Plug</p>	











# CLUTCHES — BLISSFIELD / YORK STYLE

Listed in ascending order by our part number (continued)

 <p><b>5125</b> OE# 14533 Volt - 12V Dia. - 6" Grooves - 1 Width - 1/2" A-B Dist.- 2 11/16"</p>  <p>2 Wire Plug Metripak</p>	 <p><b>5126</b> OE# 14432 Volt - 12V Dia. - 5 7/8" Grooves - Poly 6 Width - .14" A-B Dist.- 2"</p>  <p>2 Wire Plug Metripak</p>	 <p><b>5127</b> OE# 14304 Volt - 12V Dia. - 5 7/8" Grooves - Poly 6 Width - .14" A-B Dist.- 2"</p>  <p>1 Wire Plug Weatherpak</p>	 <p><b>5128</b> OE# 14372 Volt - 12V Dia. - 6 1/8" Grooves - Poly 8 Width - .14" A-B Dist.- 1 5/16"</p>  <p>2 Wire Plug Metripak</p>
 <p><b>5129</b> OE# 14565 Volt - 12V Dia. - 5 7/8" Grooves - Poly 6 Width - .14" A-B Dist.- 1 5/8"</p>  <p>2 Wire Plug Metripak</p>	 <p><b>5131</b> OE# 508888, MAM-13 Volt - 12V Dia. - 6" Grooves - 1 Width - 1/2" A-B Dist.- 2 11/16"</p>  <p>1 Wire IHC Plug</p>	 <p><b>5141</b> OE# 511199, MAN-01 Volt - 12V Dia. - 6 3/4" Grooves - 2 Width - 1/2" A-B Dist.- 2 1/4" / 2 3/4"</p>  <p>1 Wire IHC Plug</p>	 <p><b>5143</b> OE# 7925 Volt - 12V Dia. - 6" Grooves - 2 Width - 1/2" A-B Dist.- 2 11/16"</p>  <p>1 Wire IHC Plug</p>
 <p><b>5144</b> OE# 501939, 024-21590 Volt - 12V Dia. - 6" Grooves - 2 Width - 1/2" A-B Dist.- 1 3/4" / 2 1/4"</p>  <p>1 Wire Plug Weatherpak</p>	 <p><b>5145</b> OE# 024-25238 Volt - 12V Dia. - 6" Grooves - 2 Width - 1/2" A-B Dist.- 1 3/4" / 2 1/4"</p>  <p>2 Wire Plug Metripak</p>	 <p><b>5147</b> OE# 024-25320 SC Mini Only P/N# 5281 Volt - 12V Dia. - 6" Grooves - 2 Width - 1/2" A-B Dist.- 2 1/4"</p>  <p>2 Wire Plug Metripak</p>	 <p><b>5538</b> Tecumseh/York Style Compressor Shaft Key (10 per box)</p>  <p><b>5589</b> Clutch Measuring Tool</p> <p><b>Servicing Clutch</b></p> <ul style="list-style-type: none"> <li>• Clutch mounting bolts (4): use torque wrench 13 - 19 ft. lbs.</li> <li>• Center bolt: use torque wrench 20 - 25 ft. lbs.</li> </ul>

# DENSO (JOHN DEERE) — CLUTCHES

Listed in ascending order by our part number (continued)

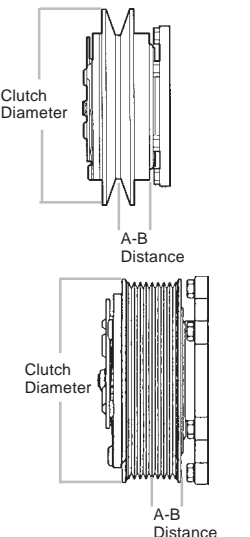
 <p><b>5017</b> 10PA17C Volt - 24v Dia. - 146mm / 5.74" Grooves - 1 A-B Dist. - 14mm</p> <p>USED ON COMPRESSORS: AT163728, TY6783</p>	 <p><b>5018</b> RECESSED HUB 10PA17C Volt - 12v Dia. - 146mm Grooves - 1 A-B Dist. - 14mm</p> <p>USED ON COMPRESSOR: RE64024</p>	 <p><b>5019</b> 10PA17C Volt - 12v Dia. - 146mm Grooves - 1 A-B Dist. - 14mm</p> <p>USED ON COMPRESSORS: RE46657, TY6626, TY6765</p>	 <p><b>5020</b> RECESSED HUB 10PA17C Volt - 12v Dia. - 146mm Grooves - 1 A-B Dist. - 14mm</p> <p>USED ON COMPRESSORS: RE55422, TY6784</p>																														
 <p><b>5021</b> RECESSED HUB 10PA17C Volt - 12v Dia. - 152mm / 5.98" Grooves - 1 A-B Dist. - 27mm</p> <p>USED ON COMPRESSORS: 4333459, AT215510</p>	<p>NOTE: DOES NOT INCLUDE DUST COVER</p>  <p><b>5022</b> 10PA15C Volt - 12v Dia. - 124.5mm / 4.90" Grooves - 8 A-B Dist. - 18.26mm</p> <p>USED ON COMPRESSOR: AL78779</p>	<p>NOTE: DOES NOT INCLUDE DUST COVER</p>  <p><b>5023</b> 10PA17C Volt - 24v Dia. - 145mm / 5.70" Grooves - 8 A-B Dist. - 29mm</p> <p>USED ON COMPRESSOR: AT168543</p>	<p>NOTE: DOES NOT INCLUDE DUST COVER</p>  <p><b>5024</b> 10PA17C Volt - 24v Dia. - 124.5mm / 5.70" Grooves - 8 A-B Dist. - 29mm</p> <p>USED ON COMPRESSOR: AT1211063</p>																														
<p>NOTE: DOES NOT INCLUDE DUST COVER</p>  <p><b>5025</b> 10PA17C Volt - 12v Dia. - 124.5mm / 4.90" Grooves - 8 A-B Dist. - 30mm</p> <p>USED ON COMPRESSOR: RE46609</p>	<p><b>Dust Covers</b></p>  <p><b>5669S</b> Replacement Dust Cover Shallow Type 5/16" thick</p>  <p><b>5669D</b> Replacement Dust Cover Deep Dish Type 7/8" thick</p>	<p><b>How to Measure</b></p>  <p>Clutch Diameter</p> <p>A-B Distance</p>	<p><b>John Deere Compressor to Clutch Chart</b></p> <table border="1"> <thead> <tr> <th>Compressor #</th> <th>Clutch Used</th> </tr> </thead> <tbody> <tr><td>4333459</td><td>5021</td></tr> <tr><td>AL78779</td><td>5022</td></tr> <tr><td>AT1211063</td><td>5024</td></tr> <tr><td>AT163728</td><td>5017</td></tr> <tr><td>AT168543</td><td>5023</td></tr> <tr><td>AT215510</td><td>5021</td></tr> <tr><td>RE46609</td><td>5025</td></tr> <tr><td>RE46657</td><td>5019</td></tr> <tr><td>RE55422</td><td>5020</td></tr> <tr><td>RE64024</td><td>5018</td></tr> <tr><td>TY6626</td><td>5019</td></tr> <tr><td>TY6765</td><td>5019</td></tr> <tr><td>TY6783</td><td>5017</td></tr> <tr><td>TY6784</td><td>5020</td></tr> </tbody> </table>	Compressor #	Clutch Used	4333459	5021	AL78779	5022	AT1211063	5024	AT163728	5017	AT168543	5023	AT215510	5021	RE46609	5025	RE46657	5019	RE55422	5020	RE64024	5018	TY6626	5019	TY6765	5019	TY6783	5017	TY6784	5020
Compressor #	Clutch Used																																
4333459	5021																																
AL78779	5022																																
AT1211063	5024																																
AT163728	5017																																
AT168543	5023																																
AT215510	5021																																
RE46609	5025																																
RE46657	5019																																
RE55422	5020																																
RE64024	5018																																
TY6626	5019																																
TY6765	5019																																
TY6783	5017																																
TY6784	5020																																

# CLUTCHES — FORD / FS SERIES

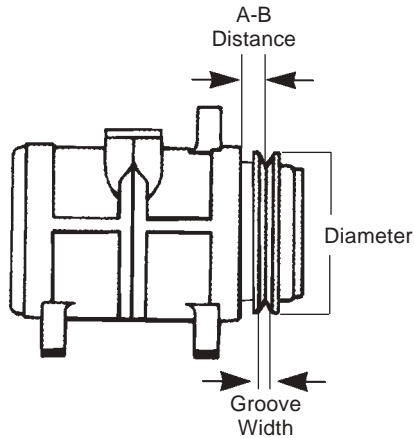

## HOW TO MEASURE:





IF PART NUMBER ON CLUTCH BEING REPLACED CANNOT BE READ, USE THE FOLLOWING PROCEDURE TO DETERMINE REQUIRED CLUTCH PART NUMBER.

1. DETERMINE IF 12 OR 24 VOLT.
2. DETERMINE IF CLUTCH IS SINGLE, DOUBLE OR MULTI-GROOVE.
3. MEASURE OUTSIDE DIAMETER OF PULLEY.
4. MEASURE WIDTH OF PULLEY GROOVE.
5. MEASURE ACCURATELY THE A-B DISTANCE.

## FORD / FS SERIES (clutches are listed in ascending order by diameter)





	PART#	DIAMETER	GROOVES	WIDTH	A-B DIST.	VOLT	DESCRIPTION
FS-6	5072	4 7/8"	Poly 6	1/8"		12	Ford FS-6
	5074	5 13/16"	1	7/16"	7/8"	12	Ford FS-6
	5075	5 13/16"	1	7/16"	1 3/8"	12	Ford FS-6
	5073F	6 1/4"	2	1/2"	3/4" / 1 7/16"	12	Ford FS-6
FS-10 FX-15	5082	4 1/2"	Poly 7	1/8"	7/8"	12	Ford FX-15
	5080	5"	Poly 6	1/8"	3/4"	12	Ford FX-15
	5081	5 5/8"	Poly 6	1/8"	3/4"	12	Ford FX-15

Listed in ascending order by our part number.

 <p><b>5072</b> OE# 1413-99 Volt - 12V      Dia. - 4 7/8" Grooves - Poly 6      Width - 1/8"</p>	 <p><b>5073F</b> OE# 1473-15, YB523 Volt - 12V      Dia. - 6 1/4" Grooves - 2      Width - 1/2" A-B Dist. - 3/4" / 1 7/16"</p> <p><i>While Supplies Last</i></p>	 <p><b>5074</b> OE# 1413-89, E8DZ-2987A Volt - 12V      Dia. - 5 13/16" Grooves - 1      Width - 7/16" A-B Dist. - 7/8"</p>	 <p><b>5075</b> OE# 1413-88 Volt - 12V      Dia. - 5 13/16" Grooves - 1      Width - 7/16" A-B Dist. - 1 3/8"</p>
---	---	---	--

# FORD / FS SERIES— CLUTCHES

Listed in ascending order by our part number.

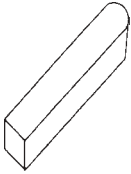
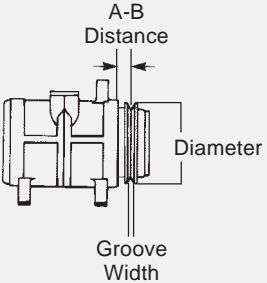
 <p><b>5080</b> OE# 1416-17 Volt - 12V      Dia. - 5" Grooves - Poly 6    Width - 1/6" A-B Dist. 3/4"</p>	 <p><b>5081</b> OE# 02-0421, FX15 21 Spline Shaft Volt - 12V      Dia. - 5 5/8" Grooves -Poly 6    Width - 1/6" A-B Dist. 3/4"</p>	 <p><b>5082</b> OE# 02-0426, FX15 21 Spline Shaft Volt - 12V      Dia. - 4 1/2" Grooves - Poly 7    Width - 1/8" A-B Dist. 7/8"</p>	 <p><b>5102</b> OE# YB591, YB627, YB3064 Ford Scroll E-Series-Diesel Grooves - 8</p>
 <p>Compressor Shaft Key</p> <p><b>5539</b> FORD Compressor Shaft Key (10 per box)</p>			



# CLUTCHES — SANDEN

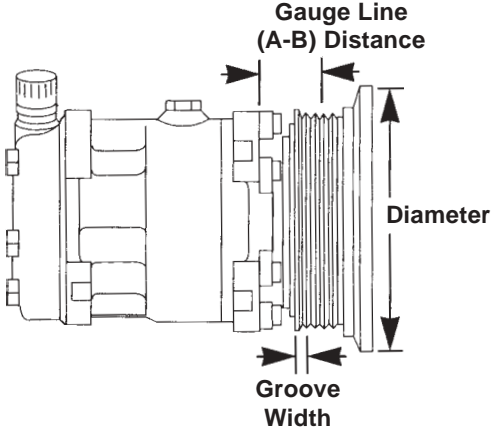

**SANDEN / SANKYO**

HOW TO MEASURE:  
 IF PART NUMBER ON CLUTCH BEING REPLACED CANNOT BE READ, USE THE FOLLOWING PROCEDURE TO DETERMINE REQUIRED CLUTCH PART NUMBER.

1. DETERMINE IF 12 OR 24 VOLT.
2. DETERMINE IF CLUTCH IS SINGLE, DOUBLE OR MULTI-GROOVE.
3. MEASURE OUTSIDE DIAMETER OF PULLEY.
4. MEASURE WIDTH OF PULLEY GROOVE.
5. MEASURE ACCURATELY THE A-B DISTANCE.

## Sanden Clutch Identification

CLUTCH

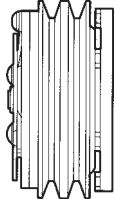
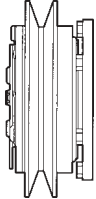
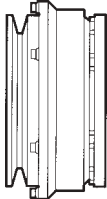
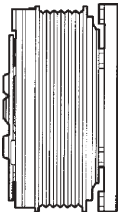
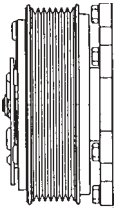
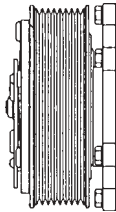
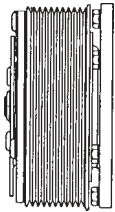
	Double Groove	Variable Groove	Offset Groove	
Single Wire Coil	 125mm (4.9") <b>Style A</b>	 158mm (6 1/4") <b>Style C</b>	 122mm (4 3/4") <b>Style D</b>	
	132mm (5 1/4") <b>Style B</b>		(OverHang)	
Double Wire Coil	125mm (4.9") <b>Style M</b>			
	132mm (5 1/4") <b>Style N</b>			
	152mm (6") <b>Style O</b>			
	6 Poly Groove	7 Poly Groove	8 Poly Groove	10 Poly Groove
Single Wire Coil	 119mm (4.6") <b>Style E</b>	 119mm (4.6") <b>Style F</b>	 119mm (4.6") <b>Style G</b>	 125mm (4.9") <b>Style H</b>
			132mm (5 1/4") <b>Style K</b>	
Double Wire Coil	125mm (4.9") <b>Style T</b>	119mm 4.6") <b>Style U</b>	119mm (4.6") <b>Style V</b>	
			130mm (5") <b>Style W</b>	
			132mm (5 1/4") <b>Style X</b>	
			152mm (6") <b>Style Y</b>	





# SANDEN — CLUTCHES

**SANDEN** (clutches are listed in ascending order by groove/diameter)

PART#	DIA.	GROOVES	WIDTH	STYLE	A-B DIST.	VOLT	DESCRIPTION
5061	4 3/4"/122mm	1	1/2	D	43.15mm	12	508/510/5H14 Overhang, 1 wire coil
5148	4 3/4"/122mm	1	1/2	D	-	12	508/510/5H14 Overhang-Ford OEM, 2 wire coil
5119	5 1/2"/138mm	1	1/2	-	-	24	709/7H15 Heavy Duty, 2 wire coil
5059	6 1/4"/158mm	1	VG	C	39.55mm	12	508/510/5H14 Heavy Duty, 1 wire coil
5121	6 3/4"/169mm	1	1/2	-	38.55mm	12	709/7H15 Ford OEM, 2 wire coil
5066	4.9"/125mm	2	1/2	A	39.55mm	12	709/7H15 1 wire coil
5123	4.9"/125mm	2	1/2	M	-	12	508/510/5H14 Ford OEM, 2 wire coil
5138	4.9"/125mm	2	1/2	M	54.55mm	12	709/7H15 2 wire coil
5139	4.9"/125mm	2	1/2	M	39.55mm	12	709/7H15 Ford OEM, 2 wire coil
5163	4.9"/125mm	2	1/2	M	-	12	7H15 Spline Shaft; 2 wire coil
5057	5 1/4"/132mm	2	1/2	B	39.55mm	12	508/510/5H14 1 wire coil
5058	5 1/4"/132mm	2	1/2	B	39.55mm	24	508/510/5H14 1 wire coil
5064	5 1/4"/132mm	2	1/2	B	39.55mm	12	709/7H15 Heavy Duty, 1 wire coil
5116	5 1/4"/132mm	2	1/2	N	39.55mm	12	709/7H15 Key Shaft; 2 wire coil
5167	5 1/4"/132mm	2	1/2	N	-	12	7H15 Spline Shaft; 2 wire coil
5065	4.6"/119mm	6	.14	E	62.55mm	12	709/7H15 1 wire coil
5164	4.9"/125mm	6	.14	T	-	12	7H15 Key Shaft; 2 wire coil
5168	4.9"/125mm	6	.14	T	-	12	7H15 Spline Shaft; 2 wire coil
5149	4.6"/119mm	7	-	F	-	12	7H15 Kodiak/Topkick #4618-9931
5060	4.6"/119mm	7	.14	F	46.55mm	12	508/510/5H14 1 wire coil
5067	4.6"/119mm	7	.14	E	46.55mm	12	709/7H15 Heavy Duty, 1 wire coil
5174	4.6"/119mm	8	-	V	-	12	7H15 2 wire, #4767-9931
5122	4.6"/119mm	8	.14	V	-	12	709/7H15 Ford OEM, 2 wire coil
5137	4.6"/119mm	8	.14	V	-	12	709/7H15 2 wire Metripak
5068	4.6"/119mm	8	.14	G	46.00mm	12	7H15 Key Shaft; 1 wire coil
5169	4.6"/119mm	8	.14	K	-	12	7H15 Spline Shaft; 2 wire Metripak
5069	4.6"/119mm	10	.14	H	50.79mm	12	508/510/5H14 1 wire coil
5176	4.68"/119mm	8	-	V	-	12	7H15 2 wire Metripak, 4776-9931
5175	5 .11"/130mm	8	-	W	-	12	7H15 2 wire Metripak, 4733-9931
5165	5 1/4"/130mm	8	.14	X	-	12	7H15 Key Shaft; 2 wire coil
5120	5 1/4"/132mm	8	.14	N	34.00mm	24	709/7H15 Heavy Duty, 2 wire coil
5177	5 .31"/135mm	8	-	X	-	12	7H15 2 wire Metripak, 4482-9931











**NOTE:** VG designates variable groove.  
 Model 5H14 replacement 24V coil is **5611**  
 Model 7H15 replacement 24V coil is **5614**  
 Model 7H15 replacement 2 wire 12V coil is **5612**  
 Model 7H Series, 12V sealed type coil is **5617**  
 Model 7H Series, 24V sealed type coil is **5618**

Listed in ascending order by our part number

			
<p><b>5057</b>                      OE# 509285                      Volt - 12V                      Dia. - 5 1/4"                      Grooves - 2                      Width - 1/2"                      Fits Model                      A-B Dist. - 39.55mm 508/510/5H14</p>	<p><b>5058</b>                      OE# 6514-6210                      Volt - 24V                      Dia. - 5 1/4"                      Grooves - 2                      Width - 1/2"                      Fits Model                      A-B Dist. - 39.55mm 508/510/5H14</p>	<p><b>5059</b>                      OE# 6521-6010                      Volt - 12V                      Dia. - 6 1/4"                      Grooves - 1VG                      Width - 7/8"                      Fits Model                      A-B Dist. - 39.55mm 508/510/5H14</p>	<p><b>5060</b>                      OE# 6520-6010                      Volt - 12V                      Dia. - 4 3/4"                      Grooves - Poly 7                      Width - .14                      Fits Model                      A-B Dist. - 46.55mm 508/510/5H14</p>





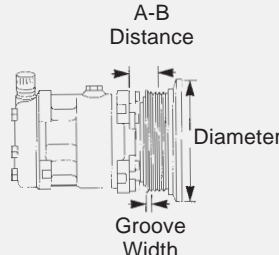





# CLUTCHES — SANDEN

Listed in ascending order by our part number (continued)

 <p><b>5061</b> OE# 61190-4409, 8545-6310 Volt - 12V Dia. - 4 15/16" Grooves - 1 Width - 1/2" Fits Model A-B Dist.- 43.15mm 508/510/5H14</p>	 <p><b>5064</b> OE# 6511-6010 Volt - 12V Dia. - 5 1/4" Grooves - 2 Width - 1/2" Heavy Duty Fits Model A-B Dist.- 39.55mm 709/7H15</p>	 <p><b>5065</b> OE# 6524-6010 Volt - 12V Dia. - 4 3/4" Grooves - Poly 6 Width - .14" Fits Model A-B Dist.- 62.55mm 709/7H15</p>	 <p><b>5066</b> OE# 6511-6110 Volt - 12V Dia. - 5" Grooves - 2 Width - 1/2" Fits Model A-B Dist.- 39.55mm 709/7H15</p>
 <p><b>5067</b> OE# 6512-6210 Volt - 12V Dia. - 4 3/4" Grooves - Poly 7 Width - .14" Heavy Duty Fits Model A-B Dist.- 46.55mm 709/7H15</p>	 <p><b>5068</b> OE# 6522-6010 Volt - 12V Dia. - 119mm, 4.6" Grooves - 8 Width - .14" Fits Model A-B Dist.- 46.00mm 7H15</p>	 <p><b>5069</b> OE# 6518-6010 Volt - 12V Dia. - 4 3/4" Grooves - Poly 10 Width - .14" Fits Model A-B Dist.- 50.79mm 508/510/5H14</p>	 <p><b>5116</b> OE# 6594-6010 Volt - 12V Dia. - 132mm Grooves - 2 Width - 1/2" 2 Wire Metripak Fits Model A-B Dist.- 39.55mm 709/7H15</p>
 <p><b>5119</b> OE# 4604-6880 Volt - 24V Dia. - 138mm Grooves - 1 Width - 1/2" Cat OE Plug Fits Model 709/7H15</p>	 <p><b>5120</b> OE# 4726-9931 used on Sanden 4726 Volt - 24V Dia. - 132mm Grooves - Poly 8 Width - .14" Cat OE Plug Fits Model A-B Dist.- 34.00mm 709/7H15</p>	 <p><b>5121</b> OE# 6506-6010 Volt - 12V Dia. - 169mm Grooves - 1 Width - 1/2" Ford OE Plug Fits Model A-B Dist.- 38.55mm 709/7H15</p>	 <p>A-B Distance Diameter Groove Width</p>



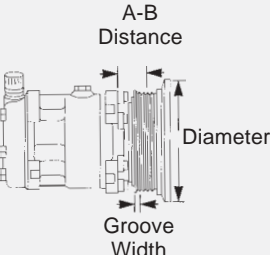

# SANDEN — CLUTCHES

Listed in ascending order by our part number (continued)

 <p><b>5122</b> OE# YB492 Volt - 12V Dia. - 119mm Grooves - Poly 8 Width - .14"</p> <p>Ford OE Plug Fits Model 709/7H15</p>	 <p><b>5123</b> OE# YB510 Volt - 12V Dia. - 125mm Grooves - 2 Width - 1/2"</p> <p>Ford OE Plug Fits Model 508/510/5H14</p>	 <p><b>5137</b> OE# 4734-6880; 4424-9931 Volt - 12V Dia. - 119mm Grooves - Poly 8 Width - .14"</p> <p>2 Wire Metripak Fits Model 709/7H15</p>	 <p><b>5138</b> OE# 6593-6010 Volt - 12V Dia. - 125mm Grooves - 2 Width - 1/2" A-B Dist.- 39.55mm</p> <p>2 Wire Metripak Fits Model 709/7H15</p>
 <p><b>5139</b> OE# 6504-6010 Volt - 12V Dia. - 132mm Grooves - 2 Width - 1/2" A-B Dist.- 39.55mm</p> <p>Ford OE Plug Fits Model 709/7H15</p>	 <p><b>5148</b> OE# YB512 Volt - 12V Dia. - 122mm Grooves - 1 Width - 1/2"</p> <p>Ford OE Plug Fits Model 508/510/5H14</p>	 <p><b>5149</b> OE# 4618-9931 Kodiak / Topkick Volt - 12V Dia. - 119mm Grooves - 7</p> <p>Wires - 2</p>	 <p><b>5163</b> OE# 4740-9931 Volt - 12V Dia. - 125mm Grooves - 2 Width - 1/2"</p> <p>2 Wire/Spline Fits Model 7H15</p>
 <p><b>5164</b> OE# 4424-9931, 4756-9931, 4793-9931 Volt - 12V Dia. - 125mm Grooves - 6 Width - .14"</p> <p>2 Wire/Key Fits Model 7H15</p>	 <p><b>5165</b> OE# 4700-9931 Volt - 12V Dia. - 130mm Grooves - 8 Width - .14"</p> <p>2 Wire/Key Fits Model 7H15</p>	 <p><b>5167</b> OE# 4777-9931 Volt - 12V Dia. - 132mm Grooves - 2 Width - 1/2"</p> <p>2 Wire/Spline Fits Model 7H15</p>	 <p>A-B Distance Diameter Groove Width</p>

# CLUTCHES — SANDEN

Listed in ascending order by our part number (continued)

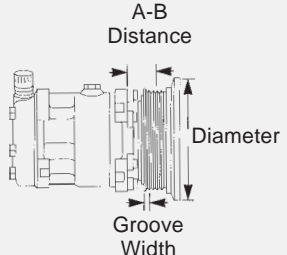
 <p><b>5168</b> OE# 4756-9931 Volt - 12V Dia. - 125mm Grooves - 6 Width - .14"</p> <p>2 Wire/Spline Fits Model 7H15</p>	 <p><b>5169</b> OE# 4816-9931 Volt - 12V Dia. - 119mm Grooves - 8 Width - .14"</p> <p>2 Wire/Spline Fits Model 7H15</p>	 <p><b>5174</b> OE# 4767-9931 Ford 7H15 #5322 Volt - 12V Dia. - 119mm Grooves - 8</p> <p>Ford Plug</p>	 <p><b>5175</b> OE# 4733-9931 Volt - 12V Dia. - 130mm, 5.11" Grooves - 8</p> <p>2 Wire</p>
 <p><b>5176</b> OE# 4776-9931 Volt - 12V Dia. - 119mm, 4.68" Grooves - 8</p> <p>2 Wire</p>	<p>Picture Not Available</p>		



**Key Shaft Armature Plate**  
• Keyed shaft can be identified by the threaded holes in the armature plate spanner. Plate has wobble notch.



**Spline Shaft Armature Plate**  
• Splined shaft can be identified by holes (not threaded) in the armature plate spanner. Plate has flat cut-out.



**5545**  
CLUTCH SNAP RING KIT - 7H15

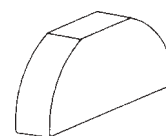

**5537**  
SANDEN/SANKYO  
Compressor Shaft Key  
(10 per box)

# SELTEC (Includes ICE) — CLUTCHES



The diagram shows a side view of a clutch assembly. It features a central hub with multiple grooves. Three dimensions are indicated with arrows: 'A-B Distance' across the top of the hub, 'Diameter' along the right side of the hub, and 'Groove Width' across the bottom of one of the grooves.

**SELTEC/ TAMA / DIESEL KIKI / ZEXEL**

IF PART NUMBER ON CLUTCH BEING REPLACED CANNOT BE READ, USE THE FOLLOWING PROCEDURE TO DETERMINE REQUIRED CLUTCH PART NUMBER.

1. DETERMINE IF 12 OR 24 VOLT.
2. DETERMINE IF CLUTCH IS SINGLE, DOUBLE OR MULTI-GROOVE.
3. MEASURE OUTSIDE DIAMETER OF PULLEY.
4. MEASURE WIDTH OF PULLEY GROOVE.
5. MEASURE ACCURATELY THE A-B DISTANCE.

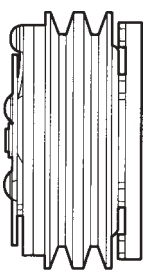
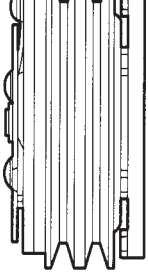
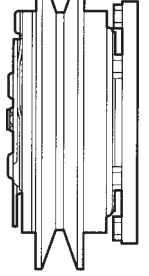
## Seltec Clutch Identification

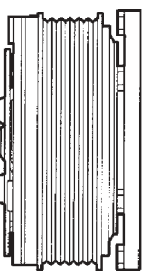
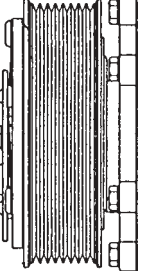
Style A	Style B	Style C	Style D	Style E	Style G
					
125mm (4.9") Double Groove	132mm (5 1/4") Double Groove	158mm (6 1/4") Variable Groove	122mm (4 3/4") Offset Groove	119mm (4.6") 6 Poly Groove	119mm (4.6") 8 Poly Groove
	<b>Style B2</b> 152mm (6") Double Groove 5 Eye				<b>Style G2</b> 152mm (6") 8 Poly groove 5 Eye











## SELTEC (clutches are listed in ascending order by diameter)

PART#	DIA.	GROOVES	WIDTH	STYLE	A-B DIST.	VOLT	DESCRIPTION
5051	4.6"/119mm	Poly 8	.14	G	34.09	12	TAMA/CH Series Male bullet
5052	4.6"/119mm	Poly 7	.14	E	35.80	12	TAMA/CH Series Male bullet
5053	4.6"/119mm	Poly 6	.14	E	34.09	12	TAMA/CH Series Male bullet
5056	4.9"/125mm	1	1/2	D	61.50	12	TAMA/CH Series Male bullet
5050	4.9"/125mm	2	1/2	A	39.60	12	TAMA/CH Series Male bullet
5055	5 1/4"/132mm	2	1/2	B	39.60	12	TAMA/CH Series Male bullet
5076	5 1/4"/132mm	2	1/2	B	39.60	12	TAMA/CH Series 3 Eyed Hub Assy
5077	5 1/4"/132mm	2	1/2	B	39.60	24	TAMA/CH Series Male bullet
5078	6"/152mm	2	1/2	B2	78	12	TM-31 only (ICE) Male bullet
5079	6"/152mm	8	.14	G2	66.5	12	TM-31 only (ICE) Male bullet
5054	6 1/4"/158mm	1 VG	-	C	39.60	12	TAMA/CH Series Male bullet

NOTE: VG designates variable groove.

# SELTEC — CLUTCHES

Listed in ascending order by our part number

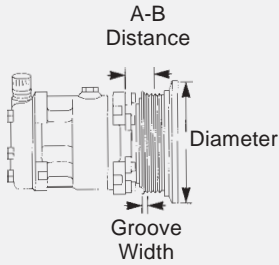
 <p><b>5050</b>            Volt - 12V            Dia. - 125mm            Grooves - 2            Width - 1/2"            A-B Dist.- 39.60mm</p>	 <p><b>5051</b>            Volt - 12V            Dia. - 119mm            Grooves - Poly 8            Width - .14            A-B Dist.- 34.09mm</p>	 <p><b>5053</b>            Volt - 12V            Dia. - 119mm            Grooves - Poly 6            Width - .14            A-B Dist.- 34.09mm</p>	 <p><b>5054</b>            Volt - 12V            Dia. - 158mm            Grooves - 1            Width - Variable            A-B Dist.- 39.60mm</p>
 <p><b>5055</b>            Volt - 12V            Dia. - 132mm            Grooves - 2            Width - 1/2"            A-B Dist.- 39.60mm</p>	 <p><b>5056</b>            Volt - 12V            Dia. - 125mm            Grooves - 1            Width - 1/2"            A-B Dist.- 61.50mm</p>	 <p><b>5076</b>            Volt - 12V            Dia. - 132mm            Grooves - 2            Width - 1/2"            A-B Dist.- 39.60mm</p>	 <p><b>5077</b>            Volt - 24V            Dia. - 132mm            Grooves - 2            Width - 1/2"            A-B Dist. - 39.60mm</p>
 <p><b>5078 (TM-31 only)</b>            Volt - 12V            Dia. - 152mm 6"            Grooves - 2            Width - 1/2"            A-B Dist. - 78mm</p>	 <p><b>5079 (TM-31 only)</b>            Volt - 12V            Dia. - 152mm 6"            Grooves - 8            Width - .14            A-B Dist. - 66.5mm</p>	 <p><b>5535</b>            SELTEC            Compressor Shaft Key            (10 per box)</p>	 <p>A-B Distance            Diameter            Groove Width</p>

# IDLER PULLEYS and ECCENTRICS — CLUTCHES

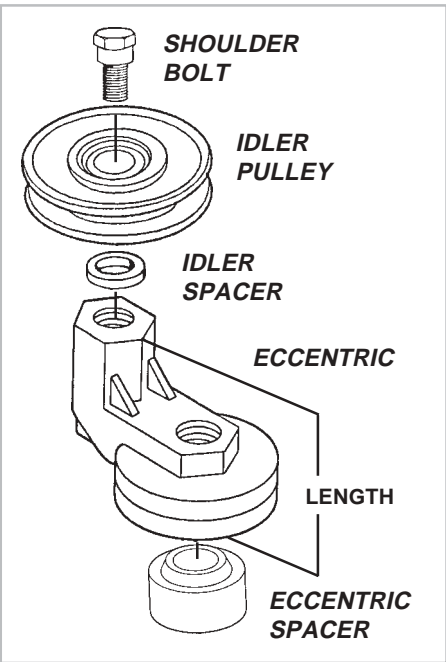

**SHOULDER BOLT**

**IDLER PULLEY**

**IDLER SPACER**

**ECCENTRIC**

**LENGTH**

**ECCENTRIC SPACER**

Thread	Part #
7/16" NF Shoulder Bolt	5655









Thickness	Part #
1/8"	5659
1/4"	5661
3/8"	5662
7/16"	5663
1/2"	5664
9/16"	5665
5/8"	5666
3/4"	5667
1"	5668

Diameter	Part #
1"	5654

Length	Part #
3/4"	5650
1"	5646
1 1/4"	5651
1 1/2"	5648
1 3/4"	5649
2"	5652
2 1/4"	5647

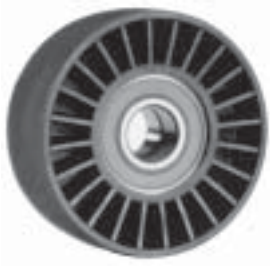
Diameter	Belt	Part #
3 1/8"	1/2"	5656
3 3/8"	1/2"	5641
3 5/8"	1/2"	5641S
4"	1/2"	5657
2"	Backside Idler	5658
3 1/4"	Backside Idler	5645

## IDLER PULLEYS and ECCENTRICS

 <p><b>5640</b> 1 1/4" SAE Bolt <b>Idler Pulley &amp; Belt Tension Kit</b> Pulley dia: 3 5/8" Belt size: 1/2" <b>5641S</b> ..... Pulley Only <b>5651</b> ..... Eccentric Only</p>	 <p><b>5660</b> <b>Caterpillar Split Pulley</b> 6 Bolt, 1/2" Belt, 8" diameter</p>	 <p><b>Flat with Flange</b> <b>5688</b> ..... 76mm (3") <b>5689</b> ..... 90mm (3 1/2")</p>	 <p><b>Flat Poly Groove with Flange</b> <b>5690</b> ... 76mm (3") 6 Groove <b>5691</b> ... 76mm (3") 7 Groove <b>5692</b> ... 90mm (3 1/2") 4 Groove</p>
 <p><b>Flat without Flange</b> <b>5693</b> ..... 76mm (3")</p>	 <p><b>Flat without Flange - Steel</b> <b>5696</b> ..... 100mm (4") <b>5697</b> ..... 76mm (3") Steel</p>	 <p><b>Flat with Flange - Steel</b> <b>5698</b> ..... 76mm (3") Steel</p>	 <p><b>5699</b> <b>Idler Pulley Replacement Bearing</b></p>