

Proper precautions must be taken to prevent personal injury from contact with moving parts, unintended engine start or other hazards present when working with powered equipment. Refer to the vehicle owners manual and/or appropriate service manual for proper safety precautions before beginning any diagnostic or repair procedures.

CONTENTS

Clutch

Maintenance 1
Lining Replacement 2
Clutch Repair 3-5
Components 6
Fan Mounting Kit 7
Fan Control Systems 7-9

Hub

Installation 9
Preventative Maintenance 10
Repair Kits: Idler Pulley 11

This fan clutch requires 90-120 PSI air pressure to DISENGAGE (6.2-8.2 bar). The air pressure is vented to ENGAGE the fan.

Any interruption of the air supply will allow the fan to run, keeping it in fail-safe mode.

Maintenance: Clutch Series

Fan clutch maintenance should be performed at every "A" PM schedule, at every oil drain, or every 25,000 miles (40,225 KM), which ever comes first.

1. Verify clutch operation. Turn key or jump the control system so that 90-120 psi air is supplied to the clutch. It should disengage and turn freely. Remove air supply. Clutch should lock up and be difficult to turn by hand.
2. With engine stopped, and clutch disengaged, check for air leaks at front of clutch and between the clutch and drive hub.
3. Check electrical and air connections at solenoid.
4. Examine wire and airline routing for damage and chafing. Repair as required.
5. Check exhaust port on solenoid for restrictions and debris. Remove any obstructions to insure positive engagement.

Clutch Lining Maintenance

It is very important to check fan clutch lining condition on a regular basis.

First Check: 100,000 miles (160,930KM)

Subsequent Checks: Every 50,000 miles (80,465KM)

System Alert Tool

This tool is a "go/no-go" gauge that will indicate whether the lining is close to wearing out and needs replacing.



1. Start with the fan clutch engaged. (No air to the clutch.) If necessary, disconnect the air line from the fan clutch.

- The clutch in the top image has a brand new lining. Notice how the tool sits down in the pocket, below the surface of the lining retention plate.
 - The clutch in the bottom image has a lining that is worn to the point where it should be replaced. Note how the tool protrudes above surface of the lining plate.
2. Order a new lining when the tool is exactly flush with the plate, and change it at the next scheduled service. Instructions for changing the lining are included in the lining kit, part# 1033-08250-01 for K22 and 1033-09340-01 for K26.

Note: Rapid lining wear indicates a problem in the fan drive control system. See page 6-8 for control system specifications and types. Call Technical Service for troubleshooting assistance, 800-927-7811.

■ Lining Replacement

The Rear Air Fan Clutch is easy to reline without removing it from the vehicle.

Tools & Parts Required

- Inch pound or Newton Meter torque wrench
- 1/4" drive ratchet
- 1/4" drive 5/16" socket
- Clutch lining kit #1033-08250-01 for K22
or #1033-09340-01 for K26

Caution:

The fan clutch must have air pressure (90-120 psi; 6.2-8.2 bar) during this procedure

1. Remove the six lining plate screws and the three lining retainer plates.
2. Remove the old lining. If the lining sticks, use a hammer and a screwdriver to free it by tapping on the dividing cut in the lining.
3. Inspect clutch shaft. If lining residue is present or if surface appears glazed over (non-metallic), temporarily release air pressure from the clutch to allow shaft to protrude, and use ScotchBrite™ to break the glaze.
4. Re-apply air pressure to the clutch, and install the new lining as shown. Some applications may be too tight to spread the lining and slip over the pulley. If necessary the lining can be cut in half with a hacksaw for installation.
5. Replace the plates and screws using the new screws supplied in the kit and torque screws to 30lbs-in. (3.4 Newton Meters).



Step 1a

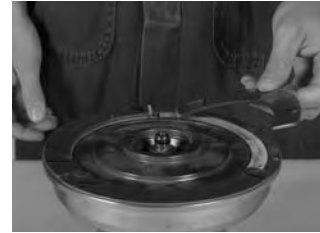

Step 1b



Step 2



Step 3



Step 4



Step 5a



Step 5b



Step 5c

Note:

Front-to-rear play at the fan blade tip with the clutch disengaged is normal and does not indicate a problem with the clutch.

Clutch Repair

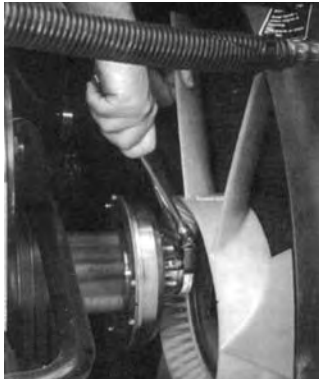

Step 1



Step 2



Step 3



Step 4a



Step 4b



Step 5

Tools & Parts Required

- Inch pound or Newton Meter torque wrench
- 5/16" and 1/2" sockets with driver
- 5/8" open end wrench

1. Remove the fan, then remove fan clutch with a flex head ratchet and 5/16" hex bit. Pressurize clutch to disengage so that holes can be lined up with 3/8" allen screws inside clutch.
2. Two carriage bolts with washers are necessary for compressing the fan clutch slightly. They should be about four inches long.
3. Alternately tighten the wing nuts until the fan clutch compresses 1/16". Caution: Do not over compress or clutch can be damaged.
4. Remove the cylinder nut and cylinder. It will be necessary to hold the opposite end of the piston rod from turning with a 5/8" open end wrench.
5. Remove the seal washer from the front of the piston rod below the cylinder cap.
6. Remove the lip seal from the large groove in the piston. Remove the dust seal from the small groove.
7. Remove the 6 lining plate screws and the 3 lining retainer plates. Remove the lining. (See lining replacement images 1- 2)
8. Inspect the two surfaces where the lining makes contact. Lining surfaces may be cleaned with ScotchBrite™. Do this before removing the housing from the shaft or abrasives may contaminate the needle bearings and result in early clutch failure.
9. Equally remove the carriage bolts and lift the housing from the shaft. Inspect needle bearing inner race on shaft. It is acceptable to have some discoloration. If cracking or scoring is found, replace the clutch. Shaft may be cleaned with a Scotch Brite pad to make inspection easier.
10. Install new front O-ring on piston rod assembly.



Step 6a



Step 6b



Step 8



Step 9



Step 9b



Step 10

Clutch Repair continued



Step 11



Step 12a



Step 12b



Step 12c



Step 12d

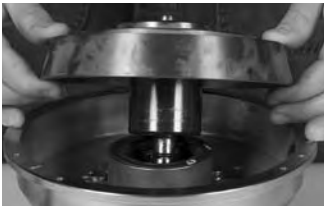

Step 12e

Torque Specs	
Clutch to Hub	45lbs-ft (61 Newton Meters)
Fan to Clutch	26lbs-ft (35.3 Newton Meters)
Front Piston Nut	84lbs-in (9.5 Newton Meters)
Lining Plate Screws	30lbs-in (3.4 Newton Meters)

11. Inspect the needle bearings in housing. If any are cracked or missing, replace the clutch.
12. Remove grease seal from the bearing housing. Use a rag to thoroughly clean needle bearings and bearing housing. Use a flat plate to press in new grease seal, lip down. Press in until flush with edge of hole. Apply grease from kit to the needle bearings and fill the spaces between the needle bearings. Push the shaft into the housing. Rotate it a few times to work the grease into the needles. Then, remove the shaft and remove any excess grease. (If there is no excess grease the first time you try this, then you have not used enough grease.) Repeat this process a few times until there are no signs of excess grease. The goal is to have a layer of grease packed within the needle bearings. Make sure no grease is present on the grease seal where it could get into the lining.
13. Place rear spring cap (small) onto piston rod. Place spring onto piston rod. Liberally lubricate inside of rear of front spring cap and place on piston rod. Wipe any grease or fingerprints from shaft where lining touches.
14. Place the housing on the shaft assembly. During final assembly, use the carriage bolts again to compress the engagement spring. Place new lining into pocket. Equally compress clutch while pushing down on lining. Stop when lining becomes flush with outer edge of clutch. Install lining plates, sharp edge down. Tighten screw to 30 lbs-in.



Step 13a



Step 13b



Step 13c



Step 13d



Step 14a



Step 14b

Clutch Repair continued



Step 14c



Step 15a



Step 15b



Step 15c



Step 16



Step 17a

15. Install the white dust seal and place the new lip seal in the piston groove with the lip facing towards the front of the fan clutch. (Up, in this picture.) Liberally grease the lip seal and the white dust seal with the grease that came with the kit.

16. Lubricate the new seal washer and place it on the piston rod.

17. Install the cylinder and torque the new nut to 84 lbs-in while holding opposite end of piston rod from turning with a 5/8" open end wrench. Release the clutch from the carriage bolts and pressurize it several times with 120 psi shop air to check for leaks and proper operation. While clutch is disengaged, line up access holes in front with bolt holes in rear. Install O-ring on rear of piston rod and lubricate with grease from kit.

18. Before installing the clutch, loosen the fan belts and check for roughness or play in the hub bearings. If problems are found, perform fan hub maintenance. Tighten the drive belts to manufactures specifications.

19. Reinstall fan clutch to fan hub using a new coupling and new nylon patch allen bolts supplied in kit. Apply air to clutch and check for normal operation.



Step 17b



Step 17c



Step 17d



Step 19a



Step 19b

Components

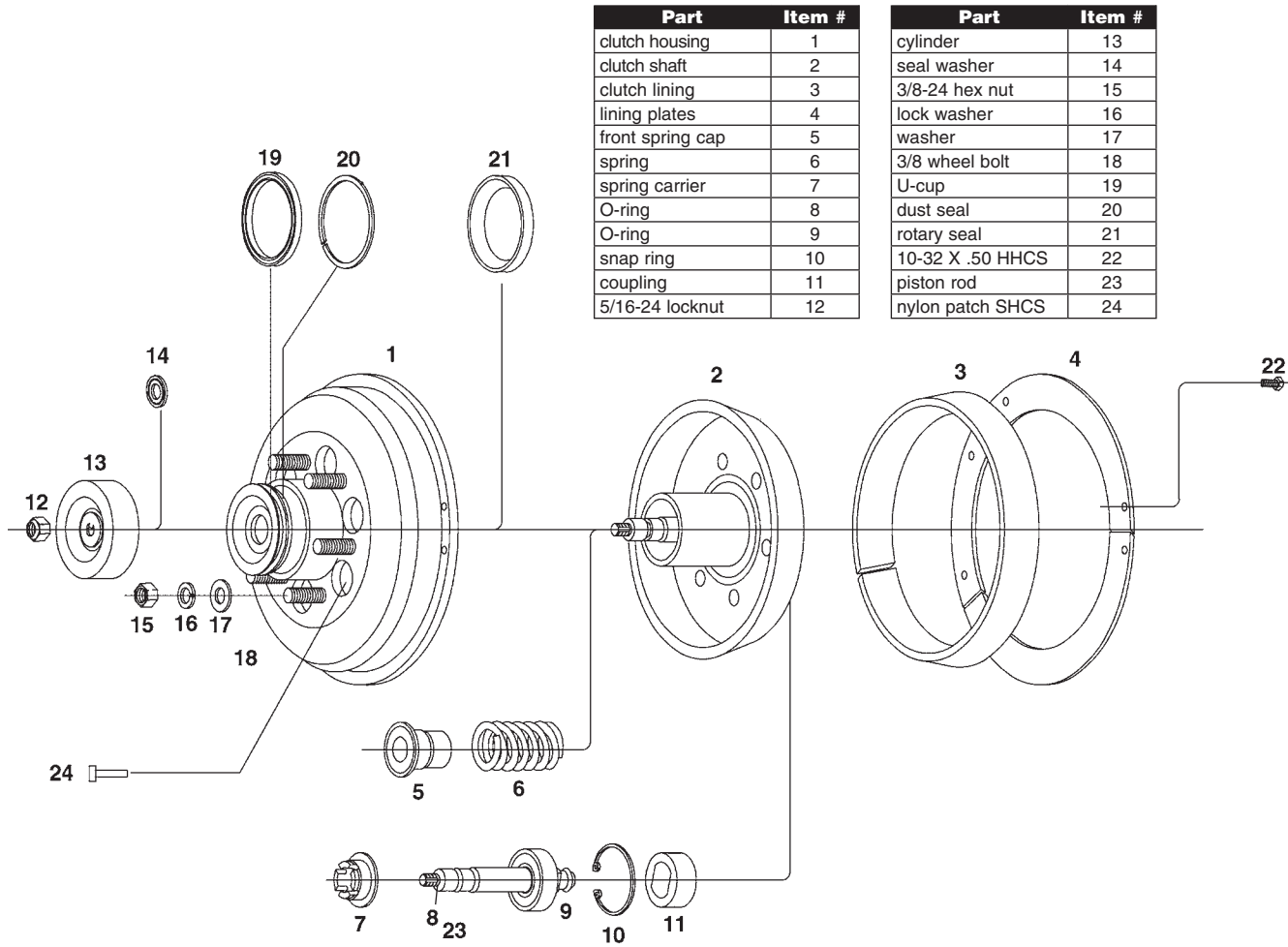

Part	Item #
clutch housing	1
clutch shaft	2
clutch lining	3
lining plates	4
front spring cap	5
spring	6
spring carrier	7
O-ring	8
O-ring	9
snap ring	10
coupling	11
5/16-24 locknut	12

Part	Item #
cylinder	13
seal washer	14
3/8-24 hex nut	15
lock washer	16
washer	17
3/8 wheel bolt	18
U-cup	19
dust seal	20
rotary seal	21
10-32 X .50 HHCS	22
piston rod	23
nylon patch SHCS	24

Kit Type	K22				K26			
	Part Number	Description	Item	Qty	Part Number	Description	Item	Qty
Service Kit	1033-05435-03	clutch lining	3	1ea	1033-09339-01	clutch lining	3	1ea
		coupling	11	1ea		coupling	11	1ea
		5/16-24 locknut	12	1ea		5/16-24 locknut	12	1ea
		seal washer	14	1ea		seal washer	14	1ea
		U-cup	19	1ea		U-cup	19	1ea
		rotary seal	21	1ea		rotary seal	21	1ea
		#10-32 X .50 HHCS	22	6ea		#10-32 X .50 HHCS	22	6ea
		dust seal	20	1ea		dust seal	20	1ea
		O-ring	9	1ea		O-ring	9	1ea
		cylinder	13	1ea		cylinder	13	1ea
		nylon patch SHCS	24	6ea		nylon patch SHCS	24	6ea
		grease packet		1ea		grease packet		1ea
Lining Kit	1033-08250-01	clutch lining	3	1ea	1033-09340-01	clutch lining	3	1ea
		10-32 x .50 HHCS	22	6ea		10-32 x .50 HHCS	22	6ea
Cylinder/Seal Kit	1033-08233-01	dust seal	20	1ea	1033-08233-01	dust seal	20	1ea
		O-ring	9	1ea		O-ring	9	1ea
		cylinder	13	1ea		cylinder	13	1ea
		U-cup	19	1ea		U-cup	19	1ea
		seal washer	14	1ea		seal washer	14	1ea
		5/16-24 locknut	12	1ea		5/16-24 locknut	12	1ea
		coupling	11	1ea		coupling	11	1ea
		grease packet		1ea		grease packet		1ea

Fan Mounting Kit for Crank Mounted Applications

Ford / Detroit Diesel ISO Mount | Crank-Mount Kit: 1097-09115-01

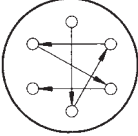

FAN MOUNTING SCREW TORQUE PATTERN
 Cross Torque fan mounting screws to 15 lbs-ft. Repeat process to 25 lbs-ft.

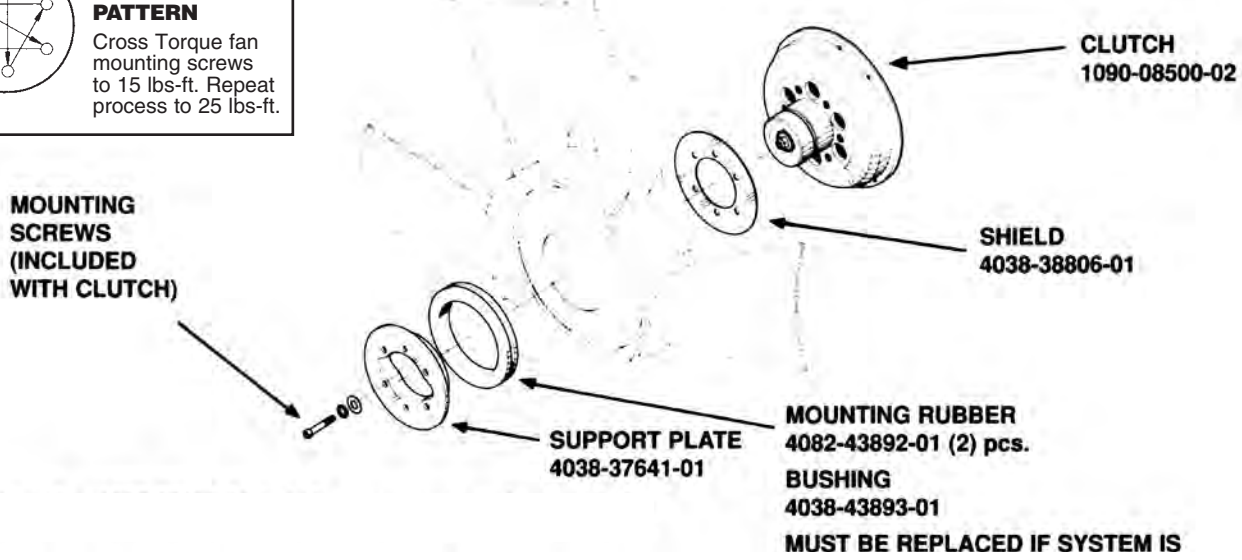

Note: Written engineering approval is required for all crankshaft applications.

Fan Control Systems

Control System Specifications

- As a minimum, control systems must be thermal switches controlling solenoid valves. Mechanical thermal valves such as the old Shutterstat® are NOT permitted.
- Air conditioning override pressure switches must have a built in hysteresis of 50psi (3.4 bar) minimum.
- If the vehicle is used in any kind of stationary operation involving a PTO or turbo unloader, there MUST be a provision in the control system to automatically lock the fan clutch ON whenever the PTO or unloader is being operated. Failure to provide this will void all warranties.
- If the vehicle is a sleeper cab and the engine is fast idled with the AC on, then a timed AC override circuit MUST be provided so that the fan clutch will not be over cycled. (The Medallion TTM® system is an example of a timed control system.)

Normally Closed Fan Clutch Control Circuit

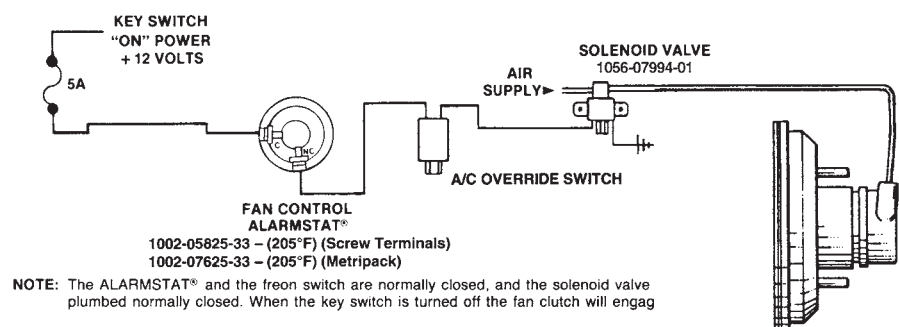

Normally Closed System With 3-Minute Timer

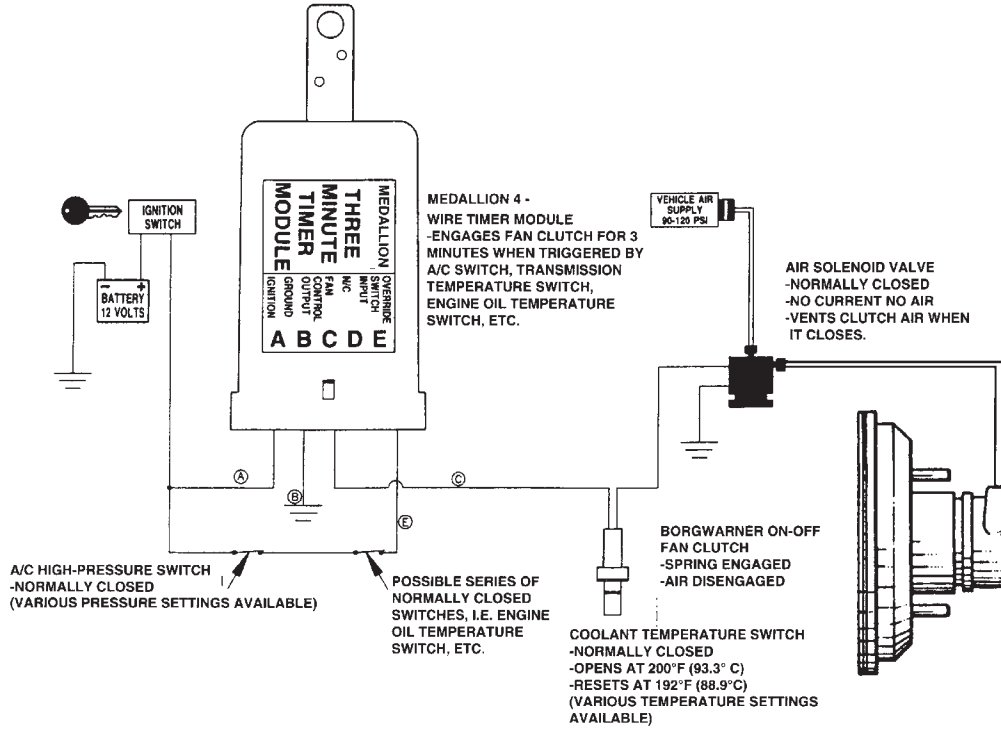

TTM® Timed Control System

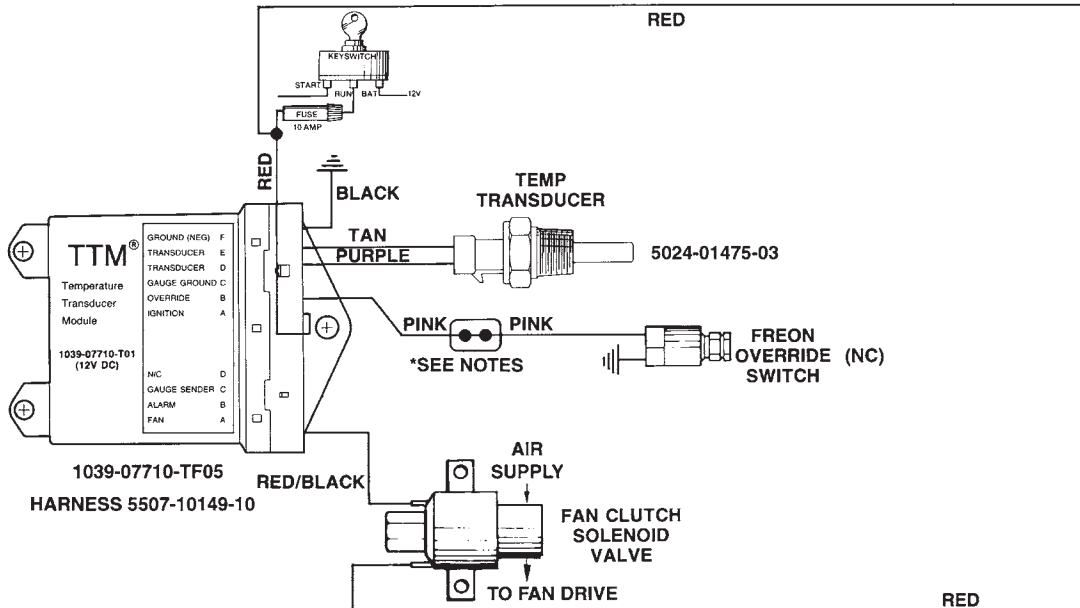

Notes: PTO/Turbo Unloader Switch: Use a pressure switch in the control circuit that will open the pink wire when the PTO or Unloader is engaged.

If required by engine manufacturer, install a normally closed charge air temperature override ALARMSTAT® 1002-04880-22.

Typical Electronic Engine Control System

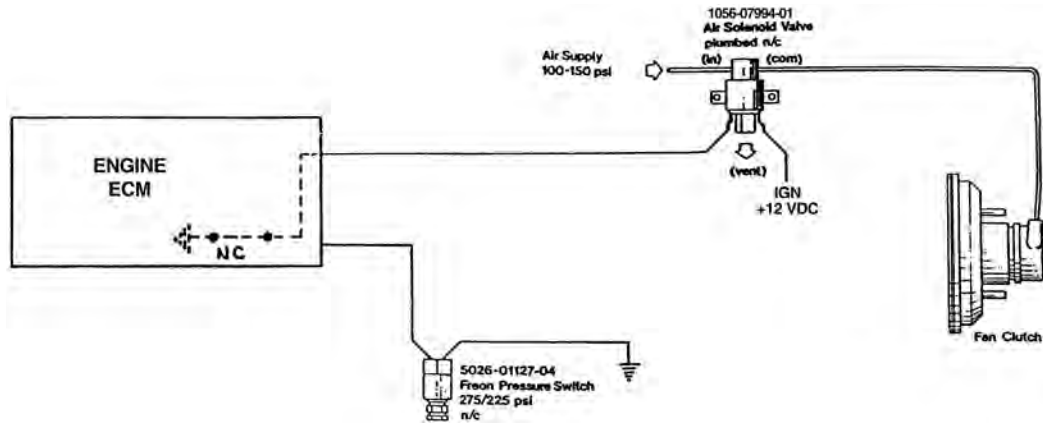

Installation: Hub Series 1077

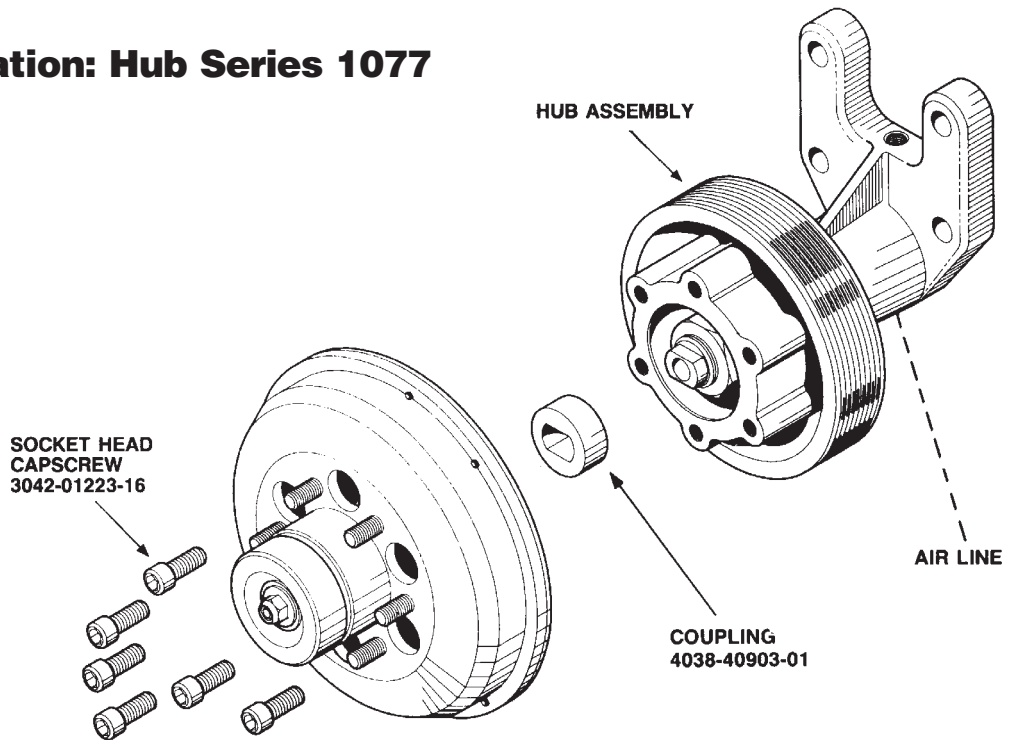

Warning: Due care and caution must be exercised when installing a fan hub. Failure to follow these instructions may cause vehicle damage, fan breakage and possible serious personal injury.

1. Attach the hub to the engine.
2. Check for proper belt tension (engine manufacturers recommendation).
3. If the fan clutch is attached, the fan may have to be put into position on the fan clutch or set into the shroud before the fan drive assembly is put into position on the engine.

Preventive Maintenance: Hub Series 1077

Periodic Checks

The Items below are to be inspected as part of fan hub preventative maintenance. We do not specify intervals as many fleets

already have preventative maintenance sheets with acceptable intervals. If preventative maintenance sheets are not available, refer to the engine manufacturers recommendations.

Maintenance Item	Action	Notes
Inspect for loose or frayed drive belts.	Replace/adjust as necessary.	Refer to engine manufacturer's belt tension specs and adjustment procedures.
Check fan hub endplay.	Verify with dial indicator if necessary. R&R and overhaul if play is present.	
Check for lube leaks.	R&R and overhaul if found.	
Check for loose attaching hardware.	Torque to specs if loose.	
Check pulley grooves for damage from belt slippage.	R&R overhaul, replace pulley if damaged.	
Periodic teardown inspection/overhaul.		Per fleet PM interval or engine manufacturers recommendations.

Repair Kits: Idler Pulley

Idler	Part Number
N14	1077-07756-01
L10	1077-07756-02
3116	1077-07756-03
3306	1077-07756-04
3306	1077-07756-05
Repair Kit	1033-07783-01

Tools & Material Required

Overhaul kit: see product catalog
 Nut: 3029-01317-03 (hub)
 Washer: 3058-01603-01 (hub)
 Pulley installer tool for
 two bearing design: 4038-42192-01
 Bearing driver that contacts outer
 race of bearing.



One Piece Bearing Design

Rear Air Fan Hubs & Idler Pulleys: One Piece Bearing Design

Overhaul is a matter of replacing the single piece bearing. Use LocTite[®] 271 on the nut, and torque it to 170 lbs-ft. (230.5 Newton Meters).



Two Piece Bearing Design

Rear Air Fan Hubs: Two Bearing Design

During overhaul, it is extremely important to use the pulley installer tool to press the pulley back onto the base. Failure to use this tool may result in damage to the bearings. Use LocTite[®]271 on the nut, and torque it to 170 lbs-ft. (230.5 Newton Meters).



231-779-7500 phone

231-775-5749 fax

800-927-7811 Customer Service

231-779-7528 Tech Service & Troubleshooting

1100 Wright Street • Cadillac, MI 49601

Lit# 21120
9/05

www.ets.borgwarner.com