

Selecting the Correct Service Valves

1. Determine Type of Fitting on Compressor Head:
 - HEAD TYPES
 - O-Ring 3/4" x 7/8"
 - Tube-O 1"-14
 - Rotalock, or
 - Flange
2. Determine Valve Needed:
 - #8 Discharge (low side)
 - #10 Suction (high side)
3. Determine Hose End Fitting Type:
 - Beadlock
 - Flare, or
 - O-Ring
4. Service Valve Port Locations and Type:
 - R12 Port 1/4" (7/16 -20 thread)
 - R134a Port 13mm used on Suction (high side)
 - R134a Port 16mm used on Discharge (low side)
5. Backseat Seat Type: Incorporates a valve which can be set at three different positions to control A/C system refrigerant flow.
 - Open
 - Mid-way, or
 - Closed



COMPRESSORS

SERVICE VALVES

1"-14 TUBE-O RING 262

3/4"x7/8" O-RING TYPE 263

FLANGE 262

FORD / FS SERIES 263

HEAD FITTING TYPES 261

ROTALOCK 262

Related Items

Adapters 268

Assortments (caps, cores, retrofit) 267

Compressor Conversion Brackets 272

Compressor Gasket Kits 271

Compressor Shaft Keys 269

RetroFit Adapters and Fittings 268

RetroFit Adapters w/Switch Port Mounts 269

Rotalock/Tube-O Seals 261

Schrader Valve Cores 455

Service Caps 266

Shaft Seal Kits 270

Tools and Service Items 456

HEAD FITTING TYPES

CCI/YORK, BLISSFIELD/TECUMSEH STYLE

Typical Examples:

ROTALOCK
Uses white teflon seal
1/2" (#8) x 5/8" (#10)

FLANGE
Uses paper gasket or square cut O-Ring

Typical Example:

1" -14 TUBE-O RING
Uses HNBR (green) O-Ring



1" -14 Tube-O Service Valves are interchangeable, and can be used on both upright or rotary type compressors.

DIESEL KIKI, ICE, SANDEN, SELTEC, TAMA, ZEXEL

Typical Examples:

3/4" x 7/8" O-RING FITTING

Vertical

Horizontal

Uses: (1) #8 and (1) #10 O-Ring
#8 Discharge use O-Ring #0013
#10 Suction use O-Ring #0015

Typical Example:

1" -14 TUBE-O RING FITTING

Vertical

Uses: (2) #10 O-Rings
Discharge use O-Ring #0015
Suction use O-Ring #0015

COMPRESSOR — SERVICE VALVES

Service Valve Specifications

NOTE: Also refer to AEROQUIP section for E-Z CLIP service valve types.







COMPRESSOR FITTING TYPE	HOSE END FITTING TYPE	HOSE END FITTING	SIZE	PART#	PORT TYPE	PORT DESCRIPTION	PORT LOCATION	NOTES
FLANGE HEAD - CCI / YORK - TECUMSEH / BLISSFIELD COMPRESSORS ONLY								
Flange	O'Ring	#8	3/4"	5425	R134a	16mm (high side)	Back	
Flange	O'Ring	#10	7/8"	5426	R134a	13mm (low side)	Back	
ROTALOCK HEAD w/TEFLON SEAL - CCI / YORK - TECUMSEH / BLISSFIELD COMPRESSORS ONLY								
Rotalock	Beadlock	#8	-	5420	R12	1/4" (7/16 -20)	Back	
Rotalock	Beadlock	#10	-	5421	R12	1/4" (7/16 -20)	Back	
Rotalock	Beadlock	#8	-	5430	R134a	16mm (high side)	Back	
Rotalock	Beadlock	#10	-	5431	R134a	13mm (low side)	Back	
Rotalock	Flare	#8	3/4"	5448	R12	1/4" (7/16 -20)	Back	
Rotalock	Flare	#10	7/8"	5447	R12	1/4" (7/16 -20)	Back	
Rotalock	Flare	#8	3/4"	5508	R12	1/4" (7/16 -20)	Side	Backseat
Rotalock	Flare	#10	7/8"	5510	R12	1/4" (7/16 -20)	Side	Backseat
Rotalock	O'Ring	#8	3/4"	5408	R12	1/4" (7/16 -20)	Side	Backseat
Rotalock	O'Ring	#10	7/8"	5401	R12	1/4" (7/16 -20)	Side	Backseat
Rotalock	O'Ring	#8	3/4"	5449	R12	1/4" (7/16 -20)	Back	
Rotalock	O'Ring	#10	7/8"	5450	R12	1/4" (7/16 -20)	Back	
Rotalock	O'Ring	#8	3/4"	5511	R134a	16mm (high side)	Back	
Rotalock	O'Ring	#10	7/8"	5512	R134a	13mm (low side)	Back	
Rotalock	O'Ring	#8	3/4"	5515	R134a	16mm (high side)	Top	Backseat
Rotalock	O'Ring	#10	7/8"	5516	R134a	13mm (low side)	Top	Backseat
1"-14 TUBE-O-RING								
Tube-O'Ring	Beadlock	#8	-	4320	R12	1/4" (7/16 -20)	on tube	Straight
Tube-O'Ring	Beadlock	#10	-	4321	R12	1/4" (7/16 -20)	on tube	Straight
Tube-O'Ring	Beadlock	#8	-	4324	R12	1/4" (7/16 -20)	on tube	90°
Tube-O'Ring	Beadlock	#10	-	4325	R12	1/4" (7/16 -20)	on tube	90°
Tube-O'Ring	Beadlock	#8	-	4522/S	R134a	16mm (high side)	on tube	45°
Tube-O'Ring	Beadlock	#10	-	4523/S	R134a	13mm (low side)	on tube	45°
Tube-O'Ring	Beadlock	#8	-	4524/S	R134a	16mm (high side)	on tube	90°
Tube-O'Ring	Beadlock	#10	-	4525/S	R134a	13mm (low side)	on tube	90°
Tube-O'Ring	Beadlock	#8	-	5422	R12	1/4" (7/16 -20)	Back	
Tube-O'Ring	Beadlock	#10	-	5423	R12	1/4" (7/16 -20)	Back	
Tube-O'Ring	Beadlock	#12	-	5424	R12	1/4" (7/16 -20)	Back	
Tube-O'Ring	Beadlock	#8	-	5432	R134a	16mm (high side)	Back	
Tube-O'Ring	Beadlock	#10	-	5433	R134a	13mm (low side)	Back	
Tube-O'Ring	Beadlock	#12	-	5434	R134a	13mm (low side)	Back	
Tube-O'Ring	Flare	#8	3/4"	5506	R12	1/4" (7/16 -20)	Top	Backseat
Tube-O'Ring	Flare	#10	7/8"	5507	R12	1/4" (7/16 -20)	Top	Backseat
Tube-O'Ring	Flare	#8	3/4"	5427	R134a	16mm (high side)	Back	
Tube-O'Ring	Flare	#10	7/8"	5428	R134a	13mm (low side)	Back	
Tube-O'Ring	O'Ring	#8	3/4"	5418	R12	1/4" (7/16 -20)	Top	Backseat
Tube-O'Ring	O'Ring	#10	7/8"	5411	R12	1/4" (7/16 -20)	Top	Backseat
Tube-O'Ring	O'Ring	#8	3/4"	5451	R12	1/4" (7/16 -20)	Back	
Tube-O'Ring	O'Ring	#10	7/8"	5452	R12	1/4" (7/16 -20)	Back	
Tube-O'Ring	O'Ring	#8	3/4"	5521	(2) R12	1/4" (7/16 -20)	Top-Back	
Tube-O'Ring	O'Ring	#10	7/8"	5522	(2) R12	1/4" (7/16 -20)	Top-Back	
Tube-O'Ring	O'Ring	#8	3/4"	5513	R134a	16mm (high side)	Back	
Tube-O'Ring	O'Ring	#10	7/8"	5514	R134a	13mm (low side)	Back	
Tube-O'Ring	O'Ring	#8	3/4"	5517	R134a	16mm (high side)	Top	Backseat
Tube-O'Ring	O'Ring	#10	7/8"	5518	R134a	13mm (low side)	Top	Backseat

SERVICE VALVES — COMPRESSOR

NOTE: Also refer to AEROQUIP section for E-Z CLIP service valve types.

COMPRESSOR FITTING TYPE	HOSE END FITTING TYPE	HOSE END FITTING	SIZE	PART#	PORT TYPE	PORT DESCRIPTION	PORT LOCATION	NOTES
3/4" x 7/8" O'RING TYPE - DIESEL KIKI - ICE - SANDEN - SELTEC - ZEXEL COMPRESSORS								
# 8 O'RING	O'Ring	#8	3/4"	5523	R12	1/4" (7/16 -20)	Back	
#10 O'RING	O'Ring	#10	7/8"	5524	R12	1/4" (7/16 -20)	Back	
# 8 O'RING	O'Ring	#8	3/4"	5519	R134a	16mm (high side)	Back	
#10 O'RING	O'Ring	#10	7/8"	5520	R134a	13mm (low side)	Back	
# 6 O'RING	O'Ring	#6	5/8"	5527	R134a	16mm (high side)	Top	In-line Adapter
# 8 O'RING	O'Ring	#8	3/4"	5528	R134a	16mm (high side)	Top	In-line Adapter
#10 O'RING	O'Ring	#10	7/8"	5529	R134a	13mm (low side)	Top	In-line Adapter
#12 O'RING	O'Ring	#12	1 1/16"	5530	R134a	13mm (low side)	Top	In-line Adapter
#6 O'Ring	O'Ring	#6	5/8"	5544	No Port	N/A	N/A	90° Adapter
#8 O'Ring	O'Ring	#8	3/4"	5545	No Port	N/A	N/A	90° Adapter
#10 O'Ring	O'Ring	#10	7/8"	5546	No Port	N/A	N/A	90° Adapter
FORD / NIPPONDENSO COMPRESSORS								
M24 THREAD	O'Ring	#10	3/4"	5549	No Port	N/A	N/A	In-line Backseat
M20 THREAD	O'Ring	#8	7/8"	5548	No Port	N/A	N/A	In-line Backseat
# 8 O'RING	O'Ring	#8	3/4"	5525	No Port	N/A	N/A	
#10 O'RING	O'Ring	#10	7/8"	5526	No Port	N/A	N/A	
# 8 O'RING	O'Ring	#8	3/4"	5546	No Port	N/A	N/A	In-line Backseat
#10 O'RING	O'Ring	#10	7/8"	5547	No Port	N/A	N/A	In-line Backseat



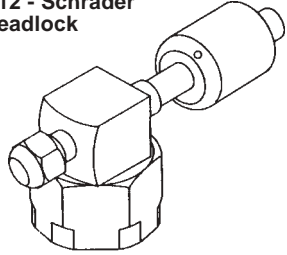
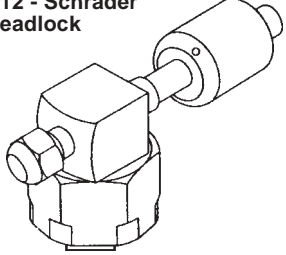







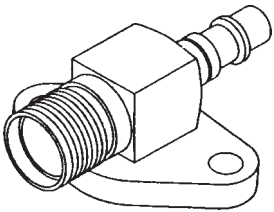





Service Valves (Listed in ascending order by our part number)

<p>Tube-O'Ring Compressor R12 - Schrader Beadlock</p>  <p><u>4320 #8 Beadlock Discharge</u> <u>4321 #10 Beadlock Suction</u></p>	<p>Tube-O'Ring Compressor R12 - Schrader 90° Beadlock</p>  <p><u>4324 #8 Beadlock Discharge</u> <u>4325 #10 Beadlock Suction</u></p>	<p>Tube-O'Ring Compressor R134a Port 45° Beadlock</p>  <p><u>4522 alum</u> <u>4522S ... steel</u> #8 Beadlock Discharge w/16mm</p> <p><u>4523 alum</u> <u>4523S ... steel</u> #10 Beadlock Suction w/13mm</p>	<p>Tube-O'Ring Compressor R134a Port 90° Beadlock</p>  <p><u>4524 alum</u> <u>4524S ... steel</u> #8 Beadlock Discharge w/16mm</p> <p><u>4525 alum</u> <u>4525S ... steel</u> #10 Beadlock Suction w/13mm</p>
<p>Rotalock Compressor R12 - Backseat O'Ring Fitting</p>  <p><u>5401 #10 O'Ring Discharge</u> <u>5408 #8 O'Ring Suction</u></p>	<p>Tube-O'Ring Compressor R12 - Backseat O'Ring Fitting</p>  <p><u>5411 #10 O'Ring Discharge</u> <u>5418 #8 O'Ring Suction</u></p>	<p>Rotalock Compressor R12 - Schrader Beadlock</p>  <p><u>5420 #8 Beadlock Discharge</u> <u>5421 #10 Beadlock Suction</u></p>	<p>Tube-O'Ring Compressor R12 - Schrader Beadlock</p>  <p><u>5422 #8 Beadlock Discharge</u> <u>5423 #10 Beadlock Suction</u> <u>5424 #12 Beadlock Suction</u></p>

(continued)







COMPRESSOR — SERVICE VALVES

Listed in ascending order by our part number (continued)

<p>Flange Compressor R134a Port O'Ring Fitting</p>  <p>5425 #8 O'Ring Discharge w/16mm 5426 #10 O'Ring Suction w/13mm</p>	<p>Tube-O'Ring Compressor R134a Port Flare Fitting</p>  <p>5427 #8 Flare Discharge w/16mm 5428 #10 Flare Suction w/13mm</p>	<p>Rotalock Compressor R134a Port Steel Beadlock</p>  <p>5430 #8 Beadlock Discharge w/16mm 5431 #10 Beadlock Suction w/13mm</p>	<p>Tube-O'Ring Compressor R134a Port Steel Beadlock</p>  <p>5432 #8 Beadlock Discharge w/16mm 5433 #10 Beadlock Suction w/13mm 5434 #12 Beadlock Suction w/13mm</p>
<p>Diesel Kiki, ICE, Sanden, Seltec 90° O'Ring Coupler Adapts to Male Insert O'Ring</p>  <p>5444 #6 5/8 -18 Female x 5/8 -18 Male 5445 #8 3/4 -16 Female x 3/4 -16 Male 5446 #10 7/8 -14 Female x 7/8 -14 Male</p>	<p>Rotalock Compressor R12 - Schrader Flare Fitting</p>  <p>5447 #10 Flare Discharge 5448 #8 Flare Suction</p>	<p>Rotalock Compressor R12 - Schrader O'Ring Fitting</p>  <p>5449 #8 O'Ring Discharge 5450 #10 O'Ring Suction</p>	<p>Tube-O'Ring Compressor R12 - Schrader O'Ring Fitting</p>  <p>5451 #8 O'Ring Discharge 5452 #10 O'Ring Suction</p>
<p>Tube-O'Ring Compressor R12 - Backseat Flare Fitting</p>  <p>5506 #8 Flare Discharge 5507 #10 Flare Suction</p>	<p>Rotalock Compressor R12 - Backseat Flare Fitting</p>  <p>5508 #8 Flare Discharge 5510 #10 Flare Suction</p>	<p>Rotalock Compressor R134a Port O'Ring Fitting</p>  <p>5511 #8 O'Ring Discharge w/16mm 5512 #10 O'Ring Suction w/13mm</p>	<p>Tube-O'Ring Compressor R134a Port O'Ring Fitting</p>  <p>5513 #8 O'Ring Discharge w/16mm 5514 #10 O'Ring Suction w/13mm</p>
<p>Rotalock Compressor R134a Port- Backseat O'Ring Fitting</p>  <p>5515 #8 O'Ring Discharge w/16mm 5516 #10 O'Ring Suction w/13mm</p>	<p>Tube-O'Ring Compressor R134a Port - Backseat O'Ring Fitting</p>  <p>5517 #8 O'Ring Discharge w/16mm 5518 #10 O'Ring Suction w/13mm</p>	<p>O'Ring Compressor R134a Port O'Ring Fitting</p>  <p>TECH TIP: USE TO ADD A SERVICE PORT TO A ROTARY COMPRESSOR.</p> <p>5519 #8 O'Ring Discharge w/16mm 5520 #10 O'Ring Suction w/13mm</p>	<p>Tube-O'Ring Compressor R12 - Schrader O'Ring Fitting</p>  <p>5521 #8 O'Ring Discharge 5522 #10 O'Ring Suction</p>

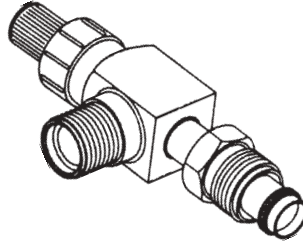
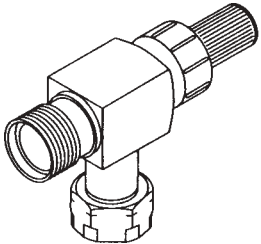
SERVICE VALVES — COMPRESSOR

Listed in ascending order by our part number (continued)







<p>O'Ring R12 - Schrader</p>  <p><u>5523 #8 O'Ring Discharge</u> <u>5524 #10 O'Ring Suction</u></p>	<p>Diesel Kiki, ICE, Sanden, Seltec O'Ring R134a Adapter</p>  <p>TECH TIP: USE TO ADD A SERVICE PORT TO A ROTARY COMPRESSOR.</p> <p><u>5527 #6 - #6 w/16mm</u> <u>5528 #8 - #8 w/16mm</u> <u>5529 #10 - #10 w/13mm</u> <u>5530 #12 - #12 w/13mm</u></p>	<p>Ford Backseat Male Insert O'Ring Male Swivel</p>  <p><u>5546 #8 O'Ring Discharge</u> <u>5547 #10 O'Ring Suction</u></p>	<p>Ford Metric Backseat Male Insert O'Ring Metric Female O'Ring</p>  <p><u>5548 M20 O'Ring Discharge</u> <u>5549 M24 O'Ring Suction</u></p>
<p>COMPRESSOR ADAPTER</p>  <p><u>5540</u> Converts Tube-O Compressor to Rotalock Compressor</p>	<p>COMPRESSOR ADAPTER</p>  <p><u>5541</u> Converts Rotalock Compressor to Tube-O Compressor</p>	 <p><u>5542S #8</u> <u>5543S #10</u> <u>5544S #12</u> GM Pad Adapters</p>	 <p><u>5545S</u> GM Hold Down Bracket</p>

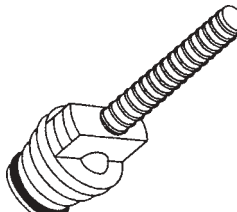
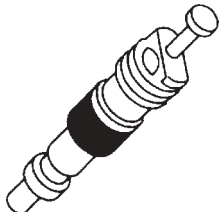
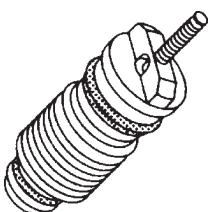
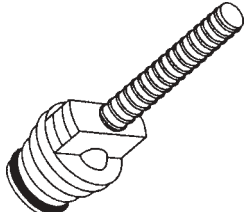
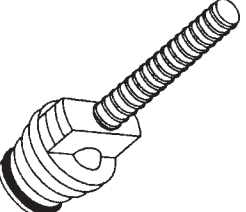

COMPRESSORS

SCHRADER VALVE CORES

NOTE: For Schrader valve service tools and kit, see section: Tools and Service Items.

 <p><u>8914</u> GM High Flow Large Bore Valve Core 10 per box</p>	 <p><u>8915</u> Replacement Valve Core Standard 1/4" Serv Port R12/R134a - 10 per box</p>	 <p><u>8916</u> Valve Core - M6 R134a Hi-Flow JRA 10 per box</p>	 <p><u>8925</u> Eaton 13mm SSV - M8 High Flow High Side 10 per box</p>	 <p><u>8926</u> Eaton 16mm SSV - M10 High Flow Low Side 10 per box</p>
---	---	--	---	--

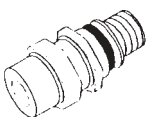
<p><u>8915</u> (20 per)</p>  <p>Universal Standard Flow Valve Core R-12 & R-134a</p>	<p><u>8916</u> (10 per)</p>  <p>High Flow JRA Valve Core - R-134a</p>	<p><u>8914</u> (10 per)</p>  <p>GM High Flow Large Bore Valve Core - R-12 & R-134a</p>	<p>(10 per)</p>  <p>STV / POA / VIR Oil Bleed Low Pressure Valve Core R-12 Only</p>	<p><u>8925</u> (5 per)</p>  <p>Eaton 13MM SSV High Flow Valve Core R-134a</p>	<p><u>8926</u> (5 per)</p>  <p>Eaton 16MM SSV High Flow Valve Core R-134a</p>
---	--	---	--	--	--

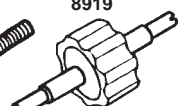
<p><u>8916</u> (3 ea.)</p> 	<p><u>5522</u> (2 ea.)</p> 
<p><u>8915</u> (10 ea.)</p> 	<p><u>8914</u> (3 ea.)</p>  <p><u>8919</u> (1 ea.)</p> 

8938
R12/R134a Schrader Valve Core Kit

8978
R134a Valve Core Repair Assortment Kit

COMPRESSOR — SERVICE PARTS

Service Caps





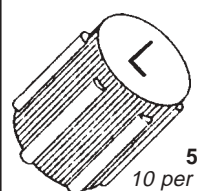
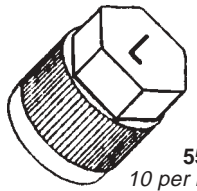
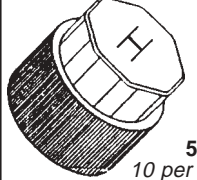
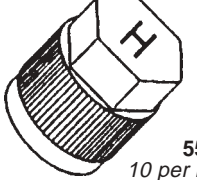
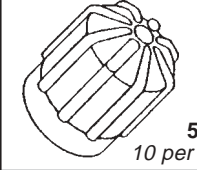
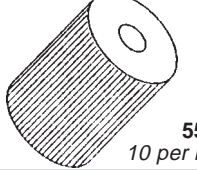
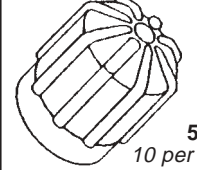
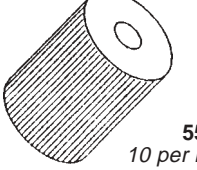

 <p>Plastic</p> <p>5531 1/4" 5532 3/16" 10 per box</p>	 <p>Brass</p> <p>5554 1/4" For Access Port on Backseat Service Valves 10 per box</p>	 <p>Plastic CCI / York- Tecumseh</p> <p>5577 1"-14 Port Caps 10 per box</p>	 <p>Black Plastic</p> <p>5578 Backseat Service Valve Cap 10 per box</p>
<p>Disable unwanted R12 1/4" and 3/16" service ports for RetroFit. Includes neoprene o'rings and threadlock.</p>  <p>Aluminum Disabler Cap</p> <p>5585 3/16" 5586 1/4" 10 per box</p>	 <p>Aluminum Port Caps Sanden / Seltec</p> <p>5581 #8 5582 #10 10 per box</p>	 <p>Brass Schrader Caps</p> <p>8901 3/16" 8902 1/4" 6 per box</p>	

R134a Service Caps













 <p>5533 10 per box</p>	<p>Color: Black Blue with L (Low Marking)</p> <p>Applications: *Bridgeport Piedmont OEM R134a 13mm Port *Bridgeport Piedmont RetroFit 13mm Adapter *Refrigeration Sales R134a RetroFit 13mm Adapter</p>	 <p>5574 10 per box</p>	<p>Color: Blue with L (Low Marking)</p> <p>Applications: *Bridgeport Piedmont OEM R134a 13mm JRA Port</p>
 <p>5534 10 per box</p>	<p>Color: Black Red with H (High Marking)</p> <p>Applications: *Bridgeport Piedmont OEM R134a 16mm Port *Bridgeport Piedmont RetroFit 16mm Adapter *Refrigeration Sales R134a RetroFit 16mm Adapter</p>	 <p>5575 10 per box</p>	<p>Color: Red with H (High Marking)</p> <p>Applications: *Bridgeport Piedmont OEM R134a 16mm JRA Port</p>
 <p>5587 10 per box</p>	<p>Color: Blue</p> <p>Applications: *Aeroquip OEM R134a 13mm Port *Aeroquip Piedmont RetroFit 13mm Adapter *Frig-C Low Side R134a RetroFit Adapter</p>	 <p>5579 10 per box</p>	<p>Color: Black</p> <p>Applications: *Eaton OEM SSV High Flow R134a 13mm Port *Refrigeration Sales CCI Service Valve w/Eaton SSV High Flow 13mm Port</p>
 <p>5588 10 per box</p>	<p>Color: Red</p> <p>Applications: *Aeroquip OEM R134a 16mm Port *Aeroquip Piedmont RetroFit 16mm Adapter *Frig-C High Side R134a RetroFit Adapter</p>	 <p>5580 10 per box</p>	<p>Color: Black</p> <p>Applications: *Eaton OEM SSV High Flow R134a 16mm Port *Refrigeration Sales CCI Service Valve w/Eaton SSV High Flow 16mm Port</p>
<p>*Bridgeport Piedmont (Schrader Bridgeport) OEM ports are typically found on some GM and Ford Vehicles. *Eaton OEM ports are typically found on some heavy duty trucks and equipment and some Ford vehicles. *Aeroquip OEM ports are typically found on Chrysler, Ford heavy duty trucks, Navistar, John Deere, some GM & Ford vehicles, and numerous import vehicles.</p>			

SERVICE PARTS — COMPRESSOR





Assortments - Caps, Cores, and Retrofit Components

8915 (20 per)  Universal Standard Flow Valve Core R-12 & R-134a	8916 (10 per)  High Flow JRA Valve Core - R-134a	8914 (10 per)  GM High Flow Large Bore Valve Core - R-12 & R-134a	8925 (5 per)  STV / POA / VIR Oil Bleed Low Pressure Valve Core R-12 Only	8926 (5 per)  Eaton 13MM SSV High Flow Valve Core R-134a	8926 (5 per)  Eaton 16MM SSV High Flow Valve Core R-134a
--	---	--	--	---	---





8938
R12/R134a Schrader Valve Core Kit

5531 (10 ea.) 1/4" Low Side 	5574 (5 ea.) 16mm Hex Red 	5575 (5 ea.) 16mm Hex Red 	5580 (5 ea.) 16mm Round Black 	5534 (5 ea.) 16mm Hex Red 	5579 (5 ea.) 13mm Round Blue 
5532 (10 ea.) 3/16" High Side 	(5 ea.) 13mm Hex Blue 	(5 ea.) 16mm Round Black 	(5 ea.) 16mm Hex Red 	(5 ea.) 14mm Round Black 	5535 (5 ea.) 14mm Round Black 













8977
Complete Charging Port Cap Kit for R12/R134a

8916 (3 ea.) 	5552 (2 ea.) 	
8915 (10 ea.) 	8914 (3 ea.) 	8919 (1 ea.) 













8978
R134a Valve Core Repair Assortment Kit

5531 (5 ea.) 1/4" Low Side 	5574 (5 ea.) 13MM Round Blue 
5532 (5 ea.) 3/16" High Side 	5575 (5 ea.) 16MM Hex Red 





8984
Small Port Cap Kit

8916 (5 per) Ford / Import JRA High Flow Valve Core 	5586 (5 per) 1/4" Black O/R Cap 	5585 (5 per) 3/16" Black O/R Cap 	5563 (3 per) GM Primary Seal Adapter 16MM O-Ring 	5564 (3 per) OEM HI Flow Port 13MM 	5565 (3 per) OEM HI Flow Port 15MM 
8914 (5 per) GM Large Bore Valve Core 	8919 (5 per) Valve Core Tool 	8889 (20 per) LABEL RETRO Blue Retro Fit Label 	5556 (14") 13MM Adapter 	5555 (5 per) (14") 16MM Adapter 	5557 (5 per) (13") 13MM Adapter 















8987
R134a Aluminum RetroFit Service Kit
Complete Kit includes everything needed to retrofit systems to R134a. Includes schrader core remover, port eliminator caps, aluminum retro charging adaptors and retrofit labels.

5532 (10 per) 3/16" R-12 Universal Cap 	(10 per) 3/16" R-12 Late Model GM Cap 	5533 (10 per) 13MM R-134a Blue Low Side Cap - OEM & Aftermarket 	5587 (3 per) 13MM R-134a Blue Low Side Cap - OEM 	8915 (10 per) Universal Standard Flow Valve Core - R-12 & R-134a 	8916 (10 per) Ford / Import JRA High Flow Valve Core - R-12 & R-134a 
5554 (10 per) Universal Cap 	(10 per) 1/4" R-12 Late Model GM Cap 	5534 (10 per) 16MM R-134a Red High Side Cap - OEM & Aftermarket 	5588 (3 per) 16MM R-134a Red High Side Cap - OEM 	8914 (10 per) GM Large Bore Valve Core - R-12 & R-134a 	5578 (10 per) Backseat Stem Cap R-12 & R-134a 

8986
Multi-Refrigerant Schrader & Port Cap Kit
A full assortment of schrader valves and charging caps.

8914 	8915 	8889 	5585 	5586 
--	--	--	--	--

8991
R134a Steel RetroFit Starter Assortment Kit
Complete steel fitting assortment, including retrofit labels, schrader cores and port eliminator caps.

5532 (10 per) 3/16" R-12 Black Plastic Universal Cap 	5531 (10 per) CP-616 1/4" R-12 Black Plastic Universal Cap 	5533 (10 per) 3/16" R-12 Late Model GM Black Plastic Cap 	5534 (10 per) 1/4" R-12 Late Model GM Black Plastic Cap 	5533 (10 per) 13MM R-134a Blue Low Side Cap - OEM & Aftermarket, Ref. Sales & OEM Parts 	5534 (10 per) 16MM R-134a Red High Side Cap - OEM & Aftermarket, Ref. Sales & OEM Parts 
8992 (10 per) 13MM R-134a Blue Low Side Cap (Aerocap / Frig-C / OEM Ports) 	5507 (10 per) 16MM R-134a Red High Side Cap (Frig-C / OEM Ports) 	5588 (10 per) 13MM R-134a Blue Low Side J.R.A. Cap (Bridgeport / Piedmont / OEM Ports) 	5574 (10 per) 16MM R-134a Red High Side J.R.A. Cap (Bridgeport / Piedmont / OEM Ports) 	5575 (5 per) 13MM R-134a Blue Low Side Cap - Eaton SSV High Flow Port 	5579 (5 per) 16MM R-134a Red High Side Cap - Eaton SSV High Flow Port 
5578 (10 per) York / Tecumseh Plastic OEM Backseat Valve Cap R-12 & R-134a 	4478 (10 per) York / Tecumseh Plastic OEM Backseat Valve Cap R-12 & R-134a 				

8992 **5507** **5588** **5574** **5575** **5579** **5580**
R12/R134a Service Cap Kit



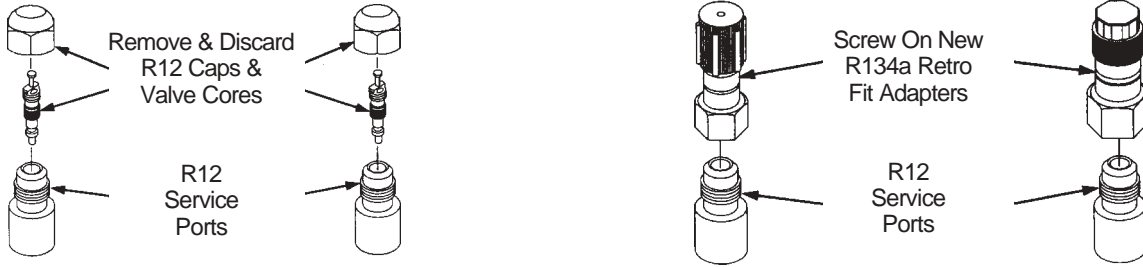

COMPRESSOR — SERVICE PARTS

RetroFit Charging Adapters and Fittings

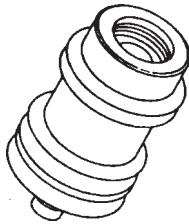

When retrofitting R12 systems to R134a, these fittings attach directly over the old R12 charging ports. Includes threadlock to prevent removal and new R134a schrader valve.

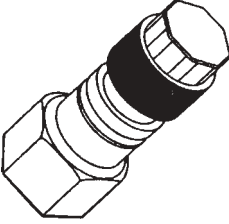
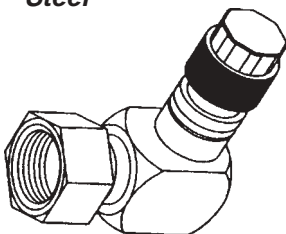
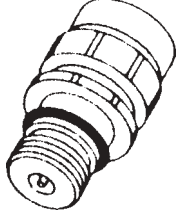
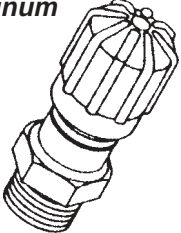
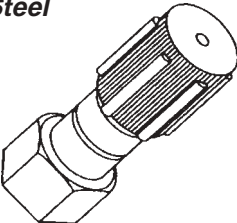
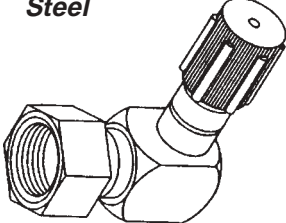
COMPRESSORS

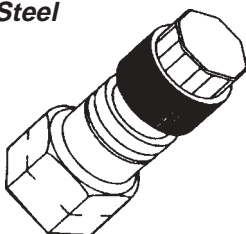
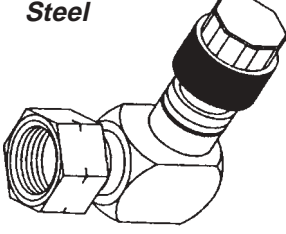
<p>Steel</p>  <p>Weld on RetroFit Fittings 5583 13mm 5584 16mm Includes Valve Core and Cap</p>	<p>Aluminum</p>  <p>5552 Primary Seal Fitting Male Thread-16mm x 1.5</p>	<p>Steel</p>  <p>red cap (high side) 5555 1/4" (7/16" -20) to 16mm, red cap Includes Valve Core, Neoprene O'Ring and Threadlock.</p>	<p>Steel</p>  <p>red cap (high side) 5558 1/4" (7/16" -20) to 16mm, red cap Includes Valve Core, Neoprene O'Ring and Threadlock.</p>
<p>Aluminum</p>  <p>5563 16mm GM Primary RetroFit Adapter Male Thread-12mm x 1.5</p>	<p>Aluminum</p>  <p>5564 13mm (1/4") 5565 16mm (3/16") OEM Hi Flow Port Includes Valve Core and Cap</p>	<p>Steel</p>  <p>blue cap (low side) 5556 1/4" (7/16" -20) to 13mm, blue cap Includes Valve Core, Neoprene O'Ring and Threadlock.</p>	<p>Steel</p>  <p>blue cap (low side) 5559 1/4" (7/16" -20) to 13mm, blue cap Includes Valve Core, Neoprene O'Ring and Threadlock.</p>
<p>Aluminum</p>  <p>5553 Low Side Primary Seal Female Thread-10mm x 1.25</p>	<p>Replacement Seals for RetroFit Fittings (20 each)</p> <p>0030 5558-5559-5560 0031 5557 0032 5555-5556</p>	<p>Steel</p>  <p>red cap (high side) 5557 3/16" (3/8" -24) to 16mm, red cap Includes Valve Core, Neoprene O'Ring and Threadlock. (Notch in nut designates 3/8")</p>	<p>Steel</p>  <p>red cap (high side) 5560 3/16" (3/8" -24) to 16mm, red cap Includes Valve Core, Neoprene O'Ring and Threadlock. (Notch in nut designates 3/8")</p>

SERVICE PARTS — COMPRESSOR

RetroFit Adapters with Switch Port Mounts

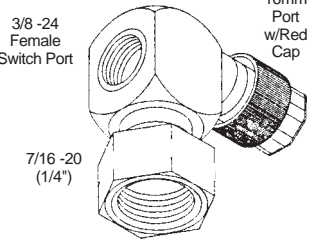
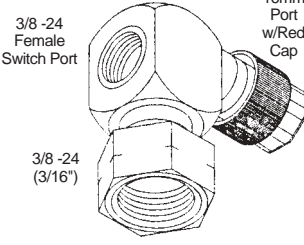
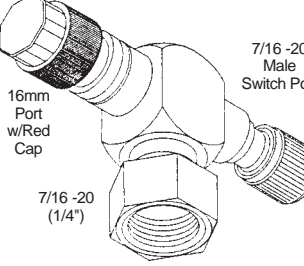
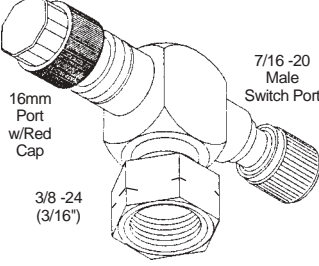
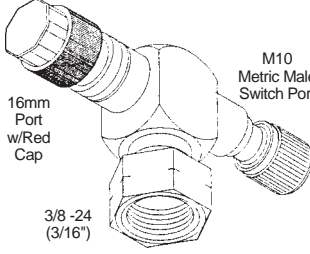
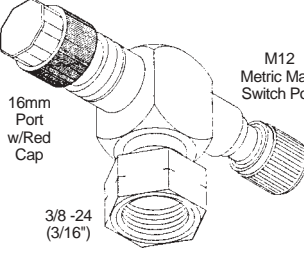
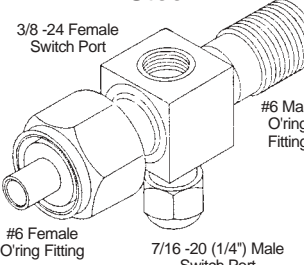
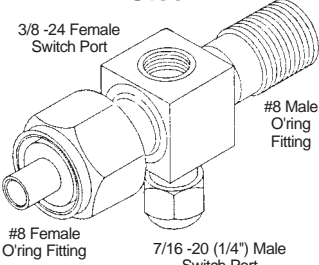
<p>Steel</p>  <p>3/8 -24 Female Switch Port 16mm Port w/Red Cap 7/16 -20 (1/4")</p> <p>5566 Includes Cap, Valve Core, Neoprene O'Ring & Threadlock</p>	<p>Steel</p>  <p>3/8 -24 Female Switch Port 16mm Port w/Red Cap 3/8 -24 (3/16")</p> <p>5567 Includes Cap, Valve Core, Neoprene O'Ring & Threadlock (Notch in nut designates 3/8")</p>	<p>Steel</p>  <p>16mm Port w/Red Cap 7/16 -20 (1/4") 7/16 -20 Male Switch Port</p> <p>5568 Includes Cap, Valve Core, Neoprene O'Ring & Threadlock</p>	<p>Steel</p>  <p>16mm Port w/Red Cap 3/8 -24 (3/16") 7/16 -20 Male Switch Port</p> <p>5569 Includes Cap, Valve Core, Neoprene O'Ring & Threadlock (Notch in nut designates 3/8")</p>
<p>Steel</p>  <p>16mm Port w/Red Cap 3/8 -24 (3/16") M10 Metric Male Switch Port</p> <p>5570 Includes Cap, Valve Core, Neoprene O'Ring & Threadlock (Notch in nut designates 3/8")</p>	<p>Steel</p>  <p>16mm Port w/Red Cap 3/8 -24 (3/16") M12 Metric Male Switch Port</p> <p>5571 Includes Cap, Valve Core, Neoprene O'Ring & Threadlock (Notch in nut designates 3/8")</p>	<p>Steel</p>  <p>3/8 -24 Female Switch Port #6 Female O'ring Fitting 7/16 -20 (1/4") Male Switch Port #6 Male O'ring Fitting</p> <p>5572 Includes Cap, Valve Core, Neoprene O'Ring & Threadlock</p>	<p>Steel</p>  <p>3/8 -24 Female Switch Port #8 Female O'ring Fitting 7/16 -20 (1/4") Male Switch Port #8 Male O'ring Fitting</p> <p>5573 Includes Cap, Valve Core, Neoprene O'Ring & Threadlock</p>

COMPRESSORS



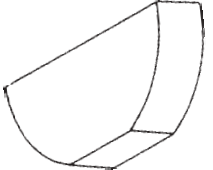
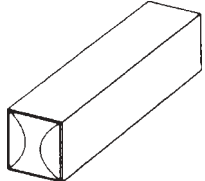
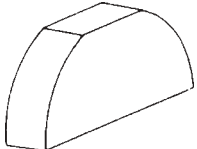
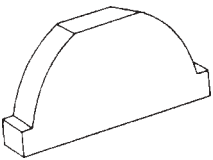
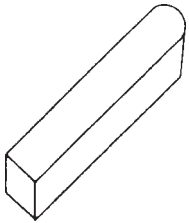



Compressor Shaft Keys

 <p>5535 <u>Seltec</u> 10 per box</p>	 <p>5536 <u>GM A6/R4</u> 10 per box</p>	 <p>5537 <u>Sanden/Sankyo</u> 10 per box</p>	 <p>5538 <u>CCI/York-Tecumseh</u> 10 per box</p>	 <p>5539 <u>Ford/Nippondenso</u> 10 per box</p>
---	---	--	--	---

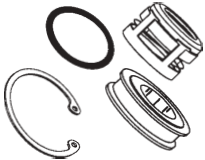
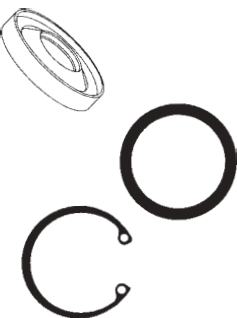
COMPRESSOR — SERVICE PARTS

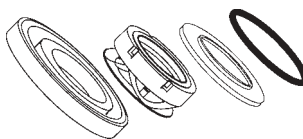
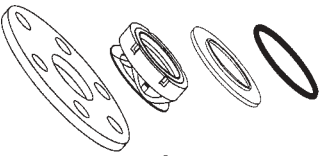
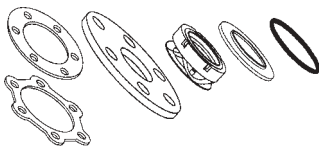
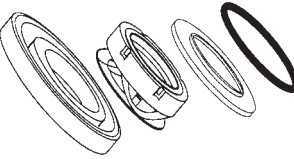
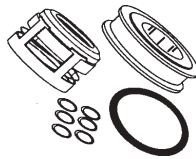
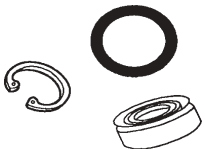
Shaft Seal Kits

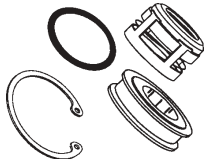
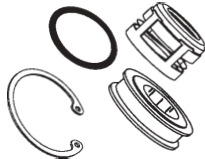
COMPRESSORS

 <p>5487 Sanden Compressor 5H14 & 7H15 Shaft Seal Kit</p>	 <p>5488 GM DA6 Compressor Shaft Seal Kit</p>	 <p>5489 GM V5 Compressor Shaft Seal Kit</p>	 <p>5490 Tecumseh Compressor HG Model Shaft Seal Kit</p>
 <p>5491 CCI York Compressor Shaft Seal Kit Large Plate, 6 Bolts, 1/4" Heads</p>	 <p>5492 Tecumseh/York Compressor Shaft Seal Kit Small Plate, 6 Bolts, 3/8" Heads</p>	 <p>5493 GM A6 & R4 Compressor Shaft Seal Kit - Ceramic</p>	 <p>5494 Ford FS6 Compressor Shaft Seal Kit</p>
 <p>5495 Diesel Kiki Compressor DKS-15CH Series Shaft Seal Kit</p>	 <p>5496 Ford FX15 Compressor Shaft Seal Kit</p>	 <p>5497 Sanden Compressor SD508 & SD510 Shaft Seal Kit</p>	 <p>5498 Sanden Compressor SD708 & SD709 Shaft Seal Kit</p>
 <p>5486 York Style - Heavy, Standard Duty, and Mini Compressor Models All Refrigerant Capability Deluxe Shaft Seal Kit Kit includes: Centering tool for proper plate orientation, Felt ring for improved dust protection and oil wick control and Clutch coil replacement anti-vibration "Super-Screws."</p>		 <p>5545 CLUTCH SNAP RING KIT - 7H15</p>	

Compressor Gasket Kits

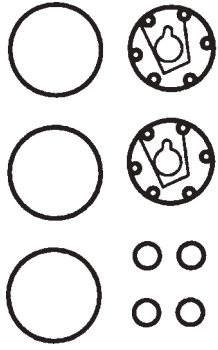
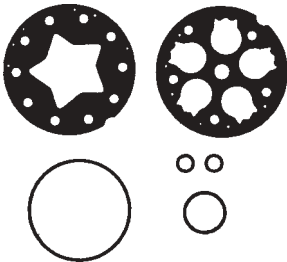
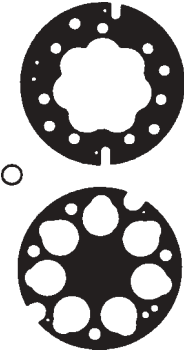
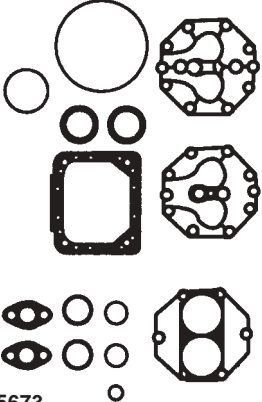
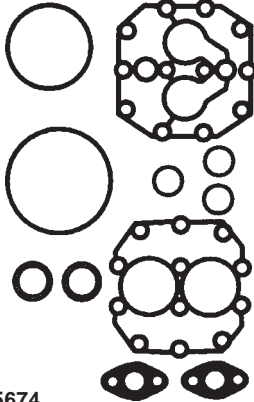
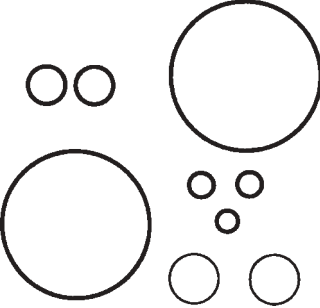
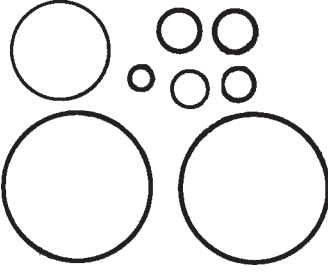
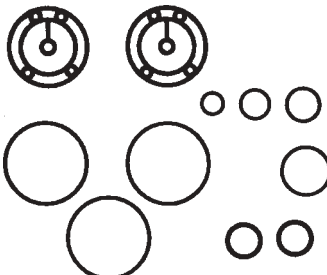
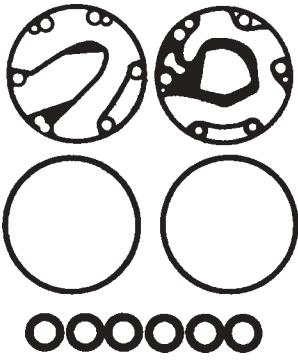
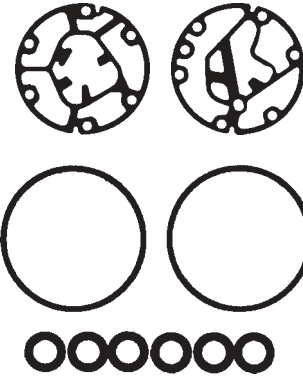
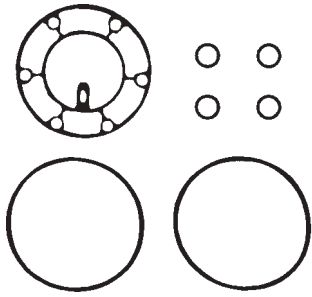
 <p>5670 Ford Nippondenso FS-6</p>	 <p>5671 Sanden 505,507,508,510,5H14</p>	 <p>5672 Sanden 708,709,7H15</p>	 <p>5673 CCI/York 206,209,210</p>
 <p>5674 Tecumseh HG850,1000</p>	 <p>5675 GM A-6</p>	 <p>5676 GM R-4</p>	 <p>5677 GM DA-6,HR-6</p>
 <p>5678 Zexel BH Diesel Kiki</p>	 <p>5679 Zexel CH Series Diesel Kiki</p>	 <p>5681 GM V5</p>	

COMPRESSOR — SERVICE PARTS

Compressor Conversion Brackets - Rotary To Upright

5500

Conversion Bracket - CAT 3406B

Replace round A/C compressor to CCI two cylinder compressor on 1984 to present Kenworth & 1988 to present Freightliner Conv. with 3406B caterpillar engine. Mounts replacement compressor in vertical position.

Use clutch:

#5044 std. duty

#5144 heavy duty w/diode & weatherpak.

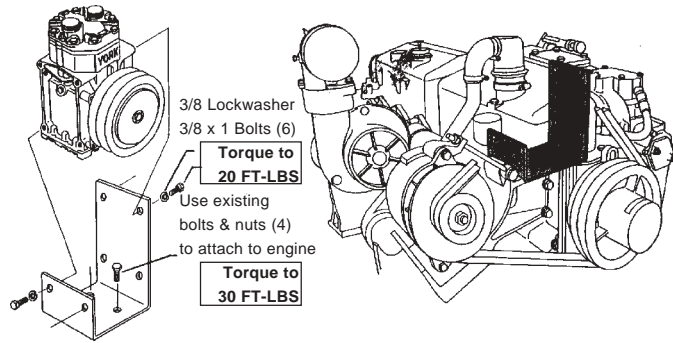

5501

Conversion Bracket - CUMMINS NTC & N14 Third Groove Drive

Replace round A/C compressor to CCI two cylinder on 1986 to present T400-800 Kenworth, Peterbilt COE & Conv., Freightliner Conv., and 1984 to present Volvo Class 8-9; all with Cummins NTC engine driving the compressor from the accessory drive third groove.

Use clutch:

#5044 std. duty

#5144 heavy duty w/diode & weatherpak.

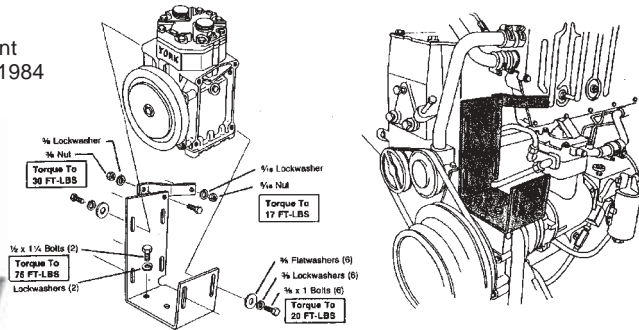

5502

Conversion Bracket - CUMMINS NTC & N14 Front Groove Drive

Replace round A/C compressor to CCI two cylinder on 1984 to present K100 & W900 Kenworth; 1985-88 Freightliner COE & Conv., all with Cummins NTC & N14 engine driving the compressor from the accessory drive front groove.

Use clutch:

KW, Freightliner

#5044 std. duty

#5144 heavy duty w/diode & weatherpak.

Peterbilt

#5031

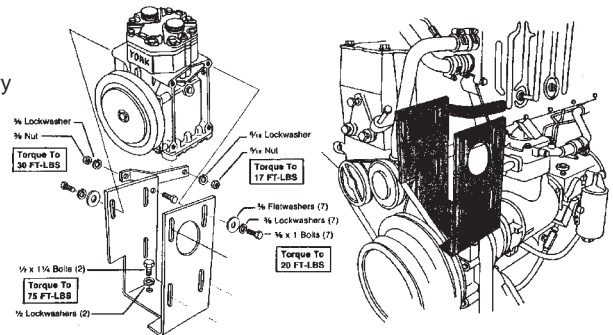

5503

Conversion Bracket - DETROIT DIESEL SERIES 60

Replace round A/C compressor to CCI two cylinder on most vehicles with Detroit Diesel Series 60 engines. The compressor is driven by the accessory drive belts which also drives the alternator.

Use clutch:

#5044 std. duty

#5144 heavy duty w/diode & weatherpak.

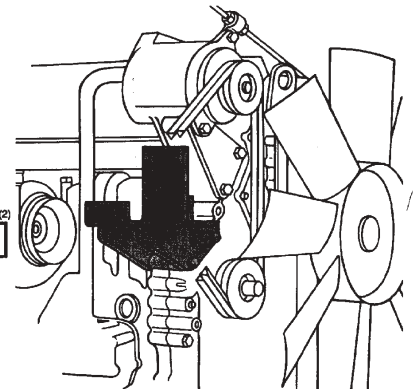
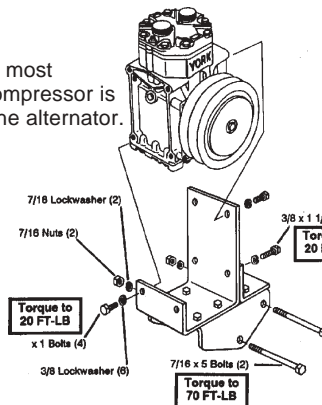

Compressor Conversion Brackets - Rotary To Upright

5504

Conversion Bracket - CUMMINS L10 & M11

Replace round A/C compressor to CCI two cylinder on most models equipped with Cummins L10 / M11 Engines. The compressor mounts on the left side of the engine and is driven by the accessory drive pulley.

Use clutch:

#5044 std. duty

#5144 heavy duty w/diode & weatherpak.

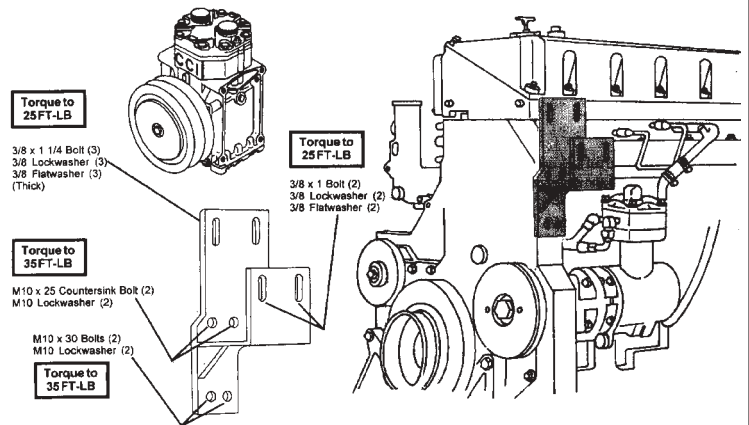

5505

Conversion Bracket - CAT 3406B

Replace round A/C compressor to CCI two cylinder on 1986 to present Peterbilt & 1985 to present Freightliner with 3406B caterpillar engine. Mounts replacement compressor in horizontal position.

Use clutch:

#5044 std. duty

#5144 heavy duty w/diode & weatherpak.

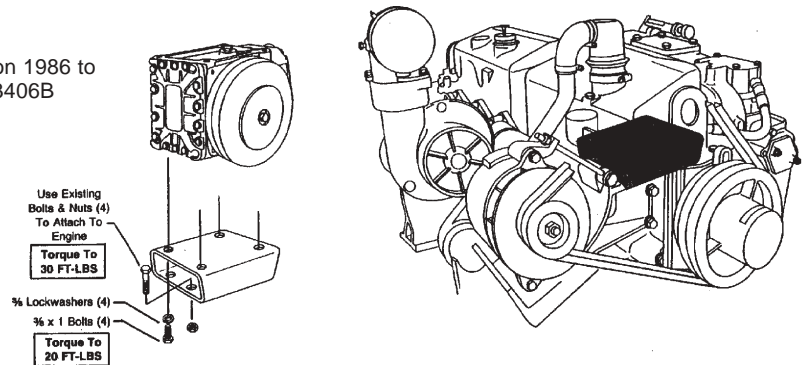

Compressor Conversion Brackets - Upright To Rotary

5633
Conversion Kit - Tecumseh/CCI York to Sanden/Seltec
Fixed compressor bracket fits most Tecumseh/York compressor mounts. Converts system to Kiki/Sanden standard mount compressors.

5623
Conversion Kit - Tecumseh/CCI York to Sanden/Seltec
Adjustable compressor bracket fits most Tecumseh/York compressor mounts. Converts system to Kiki/Sanden standard mount compressors.

COMPRESSORS